

ICOM

INSTRUCTION MANUAL

144 MHz FM TRANSCEIVER

IC-P2AT

IC-P2ET

UHF FM TRANSCEIVER

IC-P4AT

IC-P4ET

Icom Inc.



IMPORTANT

This instruction manual uses the **IC-P2AT/ET** for most of the example displays. Please note that only the frequency differs from the **IC-P4AT/ET**.

READ ALL INSTRUCTIONS carefully and completely before using the transceiver.

SAVE THIS INSTRUCTION MANUAL — This instruction manual contains important safety and operating instructions for the **IC-P2AT/ET** and **IC-P4AT/ET**.

The supplied battery pack and CPU backup battery may require a full charge prior to operation. The transceiver may require CPU resetting after charging. See p. 2 for details.

EXPLICIT DEFINITIONS

The following explicit definitions apply to this manual.

WORD	DEFINITION
CAUTION	Equipment damage may occur.
NOTE, ●	If disregarded, inconvenience only. No personal injury, risk of fire or electric shock.

CAUTIONS

NEVER connect the transceiver to an AC outlet or to a power source of more than 16 V DC. These connections will ruin the transceiver.

NEVER connect the transceiver to a power source using reverse polarity. This connection will ruin the transceiver.

NEVER allow children to touch the transceiver.

AVOID using or placing the transceiver in areas with temperatures below -10°C ($+14^{\circ}\text{F}$) or above $+60^{\circ}\text{C}$ ($+140^{\circ}\text{F}$).

AVOID placing the transceiver in direct sunlight.

AVOID the use of chemical agents such as benzine or alcohol when cleaning, as they can damage the transceiver surfaces.

BE CAREFUL! When transmitting for a long time with high output power, the rear panel will become hot.

The use of non-Icom battery packs/chargers may impair transceiver performance and invalidate the warranty.

TABLE OF CONTENTS

IMPORTANT	i	9 CALL CHANNEL	28 ~ 30	15 SET MODE	50 ~ 55
EXPLICIT DEFINITIONS	i	■ General description	28	■ Set mode construction	50
CAUTIONS	i	■ Programming the call channel	29	■ Entering SET mode	51
TABLE OF CONTENTS	ii	■ Transferring call channel contents	30	■ Setting displays	52
FOREWORD	1	10 SCAN OPERATION	31 ~ 38	16 AI FUNCTION	56 ~ 58
OPERATING NOTES	1	■ Scan types	31	■ What does AI in the transceiver do?	56
UNPACKING	1	■ Full scan	32	■ Learning function	57
1 PRE-OPERATION	2	■ Programming scan edges	33	■ Learning function on/off	57
2 PANEL DESCRIPTION	3 ~ 8	■ Programmed scan	34	■ Setting a function to the	
■ Front and side panels	3	■ Frequency skip function	35	[AI] key manually	58
■ Top panel	4	■ Setting and cancelling skip information	36	17 CLOCK AND TIMER	59 ~ 65
■ Keyboard	5	■ Memory scan	37	■ TIMER mode	59
■ Function display	7	■ Programming a skip memory channel	38	■ Setting the time	60
3 BATTERY PACK CHARGING	9 ~ 10	11 REPEATER OPERATION	39 ~ 40	■ Power-on timer	61
4 ACCESSORY ATTACHMENT	11 ~ 12	■ General description	39	■ Power-off timer	63
5 FREQUENCY SETTING	13 ~ 20	■ Operation	39	■ Auto power-off	65
■ Pre-operation	13	12 MODE CONSTRUCTION	41 ~ 42	18 OPTIONAL UNITS INSTALLATION	66
■ Using the main dial	15	■ Mode types	41	19 PAGER AND CODE SQUELCH ...	67 ~ 76
■ Dial select step	16	■ Mode arrangement chart	42	■ General description	67
■ Using the numeral keys	17	13 PRIORITY WATCH	43 ~ 46	■ Code channel	69
■ Using the Δ/∇ keys	19	■ Priority watch types	43	■ Programming a code channel	70
■ Display lighting	20	■ Memory channel watch	44	■ Pager operation	71
6 RECEIVING	21	■ Memory scan watch	45	■ Waiting for a call from a specific station	73
7 TRANSMITTING	22	■ Call channel watch	46	■ Code squelch operation	75
■ Transmitting	22	14 DTMF MEMORY	47 ~ 49	20 POCKET BEEP AND	
■ Selecting output power	22	■ General description	47	TONE SQUELCH	77 ~ 80
8 MEMORY MODE	23 ~ 27	■ Transmitting a DTMF code	47	■ Pocket beep operation	77
■ General description	23	■ Programming a DTMF memory	48	■ Tone squelch operation	79
■ Selecting MEMORY mode	23	■ Transmitting a DTMF memory	49	21 TROUBLESHOOTING	81 ~ 82
■ Selecting a memory channel	24			■ Troubleshooting	81
■ Programming a memory channel	25			■ Exiting a display	82
■ Transferring memory contents	26			22 SPECIFICATIONS	83 ~ 84
■ Masking a memory channel	27				

FOREWORD

Thank you for purchasing the **IC-P2AT/ET** or **IC-P4AT/ET FM TRANSCEIVER**.

This transceiver is a state-of-the-art handheld that fits comfortably in the palm of your hand and combines ease of use with multi-operational capabilities.

The transceiver has a "trial mode" to give access to functions according to your ability. See separate "STAR SELECTION GUIDE" for the trial mode.

OPERATING NOTES

When using the transceiver with a small-capacity battery pack such as the BP-111 or with manganese dry cell batteries in the optional BP-110, we recommend operating with low output power. Battery power will be discharged quickly if the transceiver is operated continuously using high output power.

When all of 5 star marks (★) do not appear on the function display, some functions will be deactivated. See p. 81 or the separate "STAR SELECTION GUIDE" to use the deactivated functions.

UNPACKING

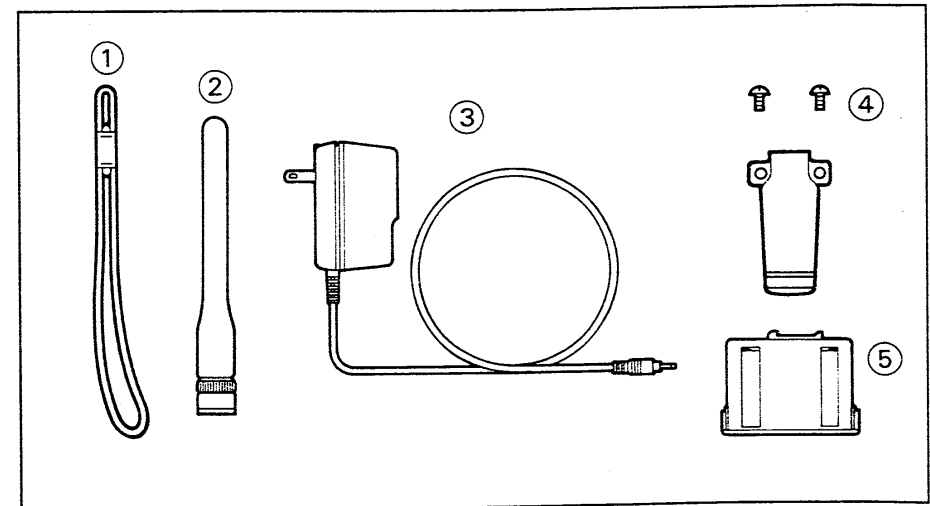

Accessories included with the transceiver:	Qty.
① Handstrap	1
② Antenna *1	1
③ Wall charger*2	1
④ Belt clip and screws	1 set
⑤ Battery pack (BP-111; attached to the transceiver)	1

*1 FA-140BF for the IC-P2AT/ET
FA-430BD for the IC-P4AT/ET

*2 Either the BC-73E/D or BC-74A/V will be attached to the transceiver depending on the version.

1. Charge the battery pack.

Connect the supplied wall charger as illustrated in the diagram below.

- The CPU backup battery will also be fully charged.
- See p. 9 for details on safety and use of a desktop charger.

to
[DC13.8V]

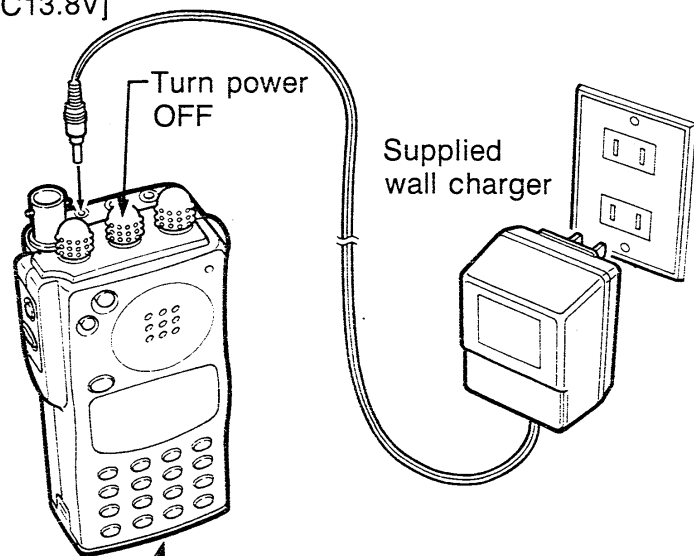

Charging period: approx. 15 hrs.

- **NEVER** charge a battery case with dry cell batteries.

2. Reset the transceiver.

While pushing the [FUNC] and [A CLR] keys, rotate [PWR/VOL] to turn power ON.

- The function display shows as follows:

VERSION	IC-P2AT/ET	IC-P4AT/ET
U.S.A.	146.01 MHz	440.00 MHz
Australia	146.01 MHz	430.00 MHz
Others	145.00 MHz	430.00 MHz

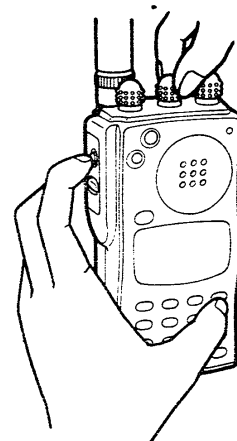

CAUTION: Resetting the CPU will clear and initialize all memory channel contents, SET mode settings, DTMF memory contents and clock and timer settings.

3. Connect the antenna.

Insert the supplied antenna into the antenna connector and rotate the antenna as shown in the diagram below.

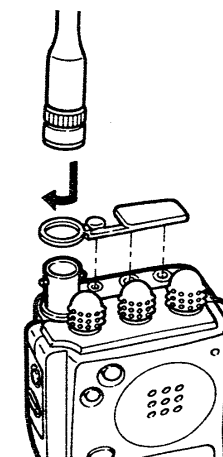

CAUTION:

Transmitting without an antenna may damage the transceiver.

2

PANEL DESCRIPTION

■ Front and side panels

FUNCTION SWITCH [FUNC] (pgs. 5, 6)

While pushing [FUNC], all switches are set for secondary function use.

- In VFO mode, the dial select function is activated. The dial select function changes the memory channel or frequency in 100 kHz or 1 MHz steps when rotating the main dial.

PTT SWITCH [PTT] (p. 22)

Push and hold to transmit; release to receive.

MONITOR SWITCH [MONI/DSEL]

Monitors an operating frequency. (p. 21)

While pushing [FUNC], push this switch to change the dial select step. (p. 16)

FUNCTION DISPLAY (pgs. 7, 8)

Indicates the operating condition.

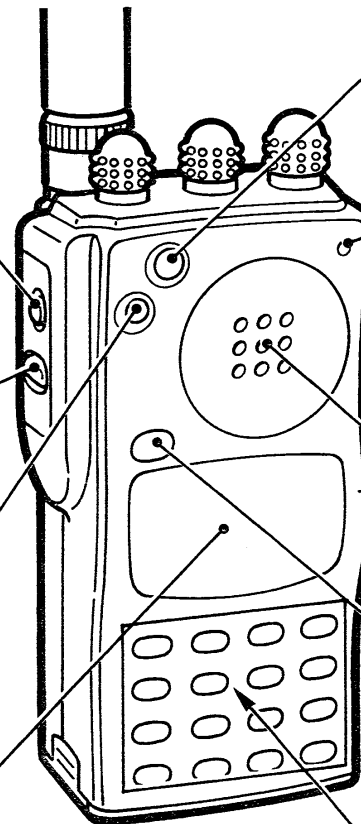

HIGH/LOW SWITCH [H/L/DTMF]

Selects HIGH or LOW output power. (p. 22)

While pushing [FUNC], push this switch to enter DTMF MEMORY mode. (p. 48)

TRANSMIT/RECEIVE INDICATOR

Lights up in green when the squelch opens; lights up in red when transmitting.

LIGHT SWITCH [LIGHT] (p. 20)

Turns the display and keyboard back-lighting ON and OFF.

SPEAKER/MICROPHONE

AI KEY [AI]

Push to activate the function indicated in the AI function indicator. (p. 57)

Enters AI selection mode when pushed and held. (p. 58)

KEYBOARD (pgs. 5, 6)

Numerical and other function keys for activating functions and tuning.

■ Top panel

EXTERNAL DC POWER JACK [DC13.8V]
 Connects the supplied wall charger for charging the battery pack. (p. 9)

Allows operation with a 13.8 V DC power source using the optional cables, CP-12 or OPC-254. (See separate "List of Options" for details.)

ANTENNA CONNECTOR (p. 2)
 Connects the supplied antenna.

SQUELCH CONTROL [SQL] (p. 21)
 Varies the squelch threshold point for noise mute.

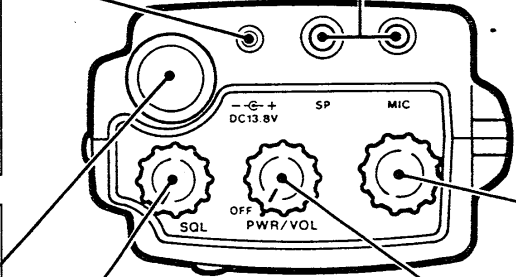

EXTERNAL SPEAKER AND MICROPHONE JACKS [SP/MIC]
 Connect an optional speaker-microphone or headset, if desired. The internal speaker and microphone will not function when either is connected. (See separate "List of Options" for details.)

MAIN DIAL
 Sets operating frequency, memory channel and SET mode contents.

VOLUME CONTROL [PWR/VOL] (p. 21)
 Turns power ON and OFF and adjusts the audio level.

2 PANEL DESCRIPTION

Keyboard

KEY	FUNCTION	SECONDARY FUNCTION (While pushing [FUNC])
T/T SQL 1	T/T SQL 1	Turns ON the following optional functions in this sequence: subaudible tone encoder → pocket beep → tone squelch → non-tone operation. (pgs. 40, 77)
PGR/C-SQL 2	PGR/C-SQL 2	Turns ON the following optional functions in this sequence: pager → code squelch → non-selective calling operation. (pgs. 71, 75)
SKIP 3	SKIP 3	Sets the selected memory channel as a skip memory channel in MEMORY mode. (p. 36)
DUP 4	DUP 4	Selects the duplex direction in this sequence: – duplex → +duplex → simplex. (p. 39)
CODE 5	CODE 5	Programs the code channel for optional pager and code squelch. (p. 70)
MASK 6	MASK 6	Hides and displays the selected memory channel in MEMORY mode. Memory channel 0 cannot be hidden. (p. 27)
PRIO 7	PRIO 7	Starts the priority watch. (p. 43)
SET 8	SET 8	<ul style="list-style-type: none"> • When selecting VFO mode: Enters SET mode. (p. 51) • When selecting DTMF MEMORY mode: Programs DTMF code. (p. 48) • When selecting MEMORY mode or the call channel: No function.
TIMER 9	TIMER 9	Enters TIMER mode. (p. 59)
CLOCK 0	CLOCK 0	<ul style="list-style-type: none"> • When the AI function indicator shows a function: Calls up the clock display. (p. 59) • When the AI function indicator shows a time: Programs the time. (p. 59)

KEY	FUNCTION	SECONDARY FUNCTION (While pushing [FUNC])
<p>△/SCAN #</p> <p>▽/SCAN *</p>	<ul style="list-style-type: none"> • When selecting VFO or MEMORY mode: Changes the operating frequency or memory channel. (pgs. 17, 24) Starts full scan or memory scan, when either key is pushed and held. (pgs. 32, 37) • When selecting SET mode, TIMER mode or time setting condition: Changes the display contents. (pgs. 50, 59) • When selecting DTMF MEMORY mode: No function. 	<ul style="list-style-type: none"> • When selecting VFO mode: Starts programmed scan. (p. 34)
<p>CLR/M▶V A</p>	<ul style="list-style-type: none"> • When selecting VFO mode: Clears input digit before entry. (p. 17) • When selecting MEMORY mode or the call channel: Returns to VFO mode. (p. 17) 	<p>When selecting MEMORY mode or call channel: Transfers the contents into VFO by pushing and holding. (pgs. 26, 30)</p>
<p>MR/MW B</p>	<ul style="list-style-type: none"> • When selecting VFO mode: Selects MEMORY mode. (p. 23) • When selecting MEMORY mode: Changes the memory channel in units of 10. (p. 24) 	<ul style="list-style-type: none"> • When selecting VFO mode: Writes the VFO contents into the memory channel by pushing and holding. (p. 25) • When selecting the call channel: Writes the VFO contents into the call channel by pushing and holding. (p. 29)
<p>C</p>	<p>Used for transmitting and programming DTMF code "C." (p. 47)</p>	<p>No function.</p>
<p>CALL/LOCK D</p>	<p>Selects the call channel. (p. 29)</p>	<p>Turns the lock function ON and OFF. (p. 14)</p>

2 PANEL DESCRIPTION

■ Function display

FUNCTION INDICATOR

Appears while the [FUNC] switch is pushed.

LOW POWER INDICATOR (p. 22)

Appears when low output power is selected.

DUPLEX INDICATOR (p. 39)

Appears when duplex is used for repeater operation.

- “DUP” appears when + duplex is selected.
- “-DUP” appears when -duplex is selected.

S/RF INDICATOR (pgs. 21, 22)

Shows the relative signal strength when receiving; shows the output power selection when transmitting.

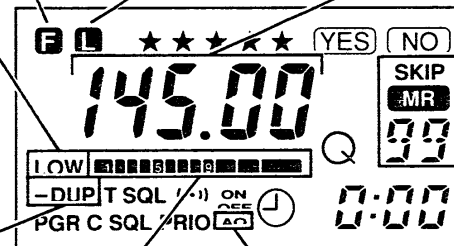

LOCK INDICATOR (p. 14)

Appears when the lock function is in use.

FREQUENCY READOUT

Shows the frequency or SET mode contents.

- The decimal point of the frequency flashes while scanning.

MEMORY CHANNEL INDICATOR

(pgs. 23, 28)

Shows the selected memory channel number.

- “MR” appears when MEMORY mode is selected.
- “SKIP” appears when the selected memory channel is set as a skip channel.
- “[]” appears when a call channel is selected.

AUTO POWER-OFF INDICATOR (p. 65)

Appears when the auto power-off function is in use.

TONE INDICATOR (pgs. 40, 77)
 Appears when an optional tone or tone squelch unit is in use.

- “T” appears when the subaudible tone encoder is used.
- “T SQL” appears when the tone squelch is used.
- “T SQL (••)” appears when the pocket beep function is in use.

PAGER INDICATOR (p. 71)
 Appears when the pager function is turned ON; flashes when a call is received.

CODE SQUELCH INDICATOR (p. 75)
 Appears when the code squelch is in use.

PRIORITY INDICATOR (p. 43)
 Appears when the priority watch is activated; flashes when the watch is paused.

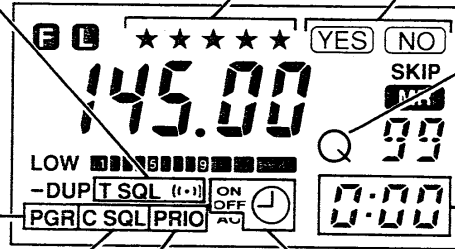

AI LEVEL INDICATOR (Separate)
 Shows the AI level.

YES/NO INDICATOR (Separate)
 Shows an answer for a trial mode question.

TRIAL MODE INDICATOR (Separate)
 Appears when the transceiver enters trial mode.

AI FUNCTION INDICATOR (p. 57)
 Shows a function of the [AI] key or the current time.

TIMER INDICATOR (pgs. 61, 63)
 Appears when the timer function is in use.

- “ON” appears when the power-on timer is in use.
- “OFF” appears when the power-off timer is in use.

3

BATTERY PACK CHARGING

Regular charging

Connect the supplied wall charger to the [DC13.8V] jack.

to
[DC13.8V]

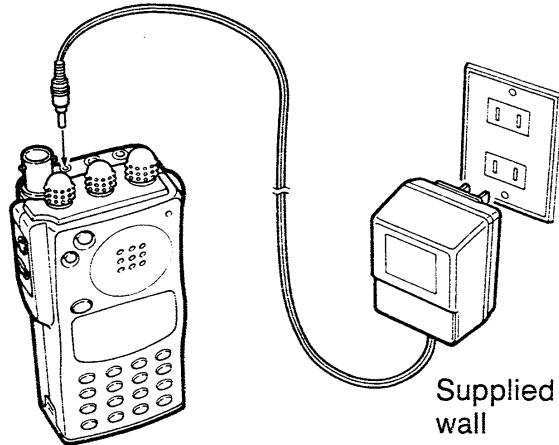

BP-111 ~ 113 or
BP-110 with NiCd
batteries
NEVER charge
the BP-110 with
dry cell batteries.

Supplied
wall
charger*

*BC-73E/D for charging BP-111 only.

• Charging period: 15 hrs. (approx.)

Rapid charging with the optional BC-80

BP-111 with transceiver

Insert the BP-111 into the transceiver.
Insert the transceiver into the charging
slot of the BC-80.

Connect the AC
adapter supplied
with the BC-80.

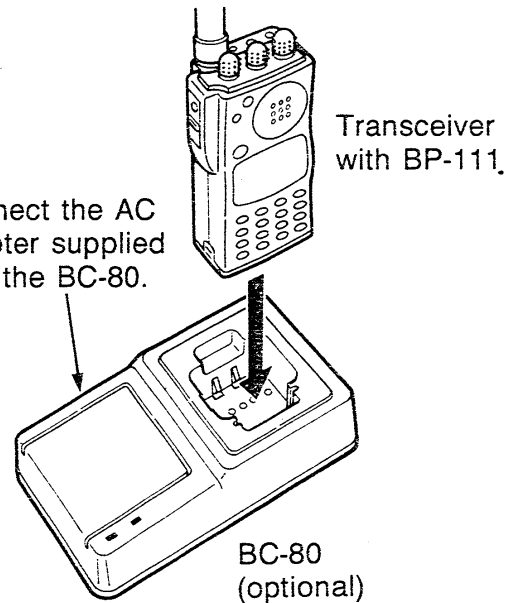

Transceiver
with BP-111.

BC-80
(optional)

● Other battery packs require an
adapter that comes with the BC-80.

• Charging period: 1~2 hrs.(approx.)

Charging with optional charger or cables

CP-12 (optional)

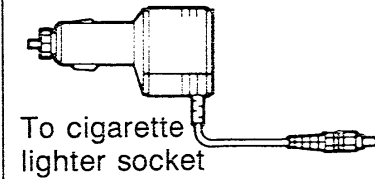

To cigarette
lighter
socket

OPC-254 (optional)

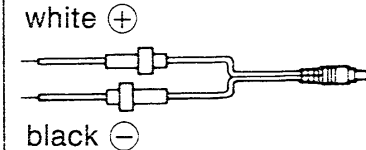

white (+)

black (-)

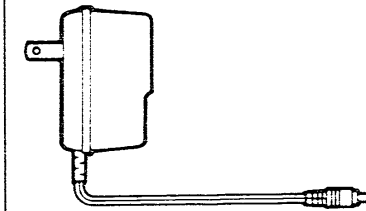

BC-74A/E/D/V
For BP-110~113
BC-73E/D
For BP-111

to
[DC13.8V]

BP-111 ~ 113
or BP-110
with NiCd
batteries

● **NEVER** connect the above options
when the BP-110 is used with dry
cell batteries.

• Charging period: 15 hrs. (approx.)

Charging of the optional BP-114

To charge the BP-114, connect the wall charger or optional cable to the charging jack.

BC-74A/E/D/V

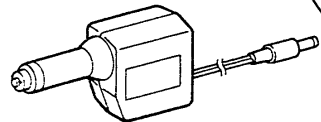
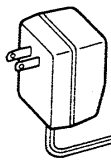

CP-12 (optional)

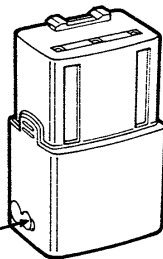

BP-114

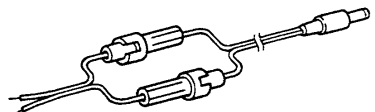

OPC-254 (optional)

The BC-73E/D cannot be used for the BP-114.

• **Charging period: 15 hrs. (approx.)**

Charging notes

NEVER attempt to charge dry cell batteries.

Connect one charger. NEVER connect two or more chargers at the same time.

Be sure to turn the transceiver power OFF during charging.

Charging may not occur in extreme cold (under 0°C; +32°F) or extreme heat (over +40°C; +104°F).

Using your battery wisely

Overcharging and complete discharging may shorten the life of a battery.

Recharging can usually be performed 300 times, but battery life can be lengthened to about 500 recharges as follows:

1. Avoid overcharging. The charging period should be less than 48 hours.
2. Use the battery until it is almost completely discharged under normal conditions. We recommend battery charging as soon as transmitting becomes impossible.

Battery life

The operating periods vary for different battery packs.

Condition:

Transmitting at high power for 1 min., receiving for 1 min. and standby for 8 min.

BATTERY	OUTPUT VOLTAGE	APPROX. OPERATING PERIOD*	
		IC-P2AT/ET	IC-P4AT/ET
BP-111	7.2 V	3 h. 40 m.	2 h. 40 m.
BP-112	7.2 V	6 h. 20 m.	4 h. 40 m.
BP-113	7.2 V	10 h.	7 h. 20 m.
BP-114	12.0 V	2 h. 40 m.	2 h.

*Operating period varies depending on operating conditions such as output power, temperature, etc.

4

ACCESSORY ATTACHMENT

Handstrap

The handstrap is convenient for carrying the transceiver.

Attach the handstrap as shown in the diagram below.

1. Insert the handstrap using a pointed instrument such as a mechanical pencil.

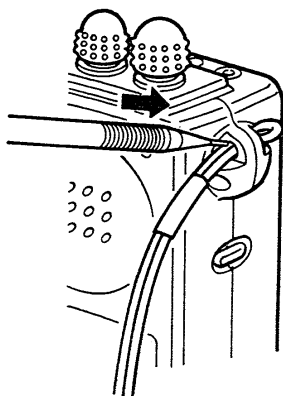

2. Put one end of the handstrap through the other end's loop.

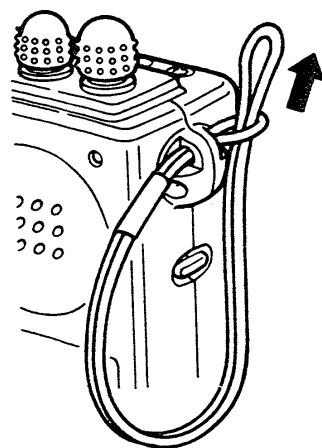

3. Pull the handstrap to tighten the knot.

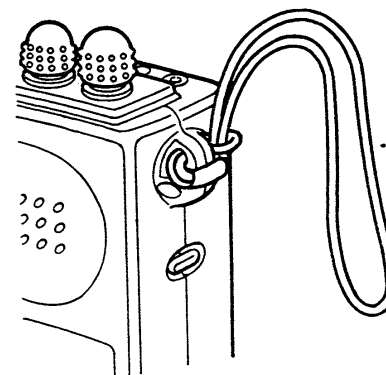

Belt clip

The belt clip allows you to attach the transceiver to your belt.

Remove the plastic screws to attach the belt clip.

To use an optional MB-20 ALLIGATOR CLIP to the transceiver, use the screws supplied with the transceiver. NEVER use the screws supplied with the alligator clip.

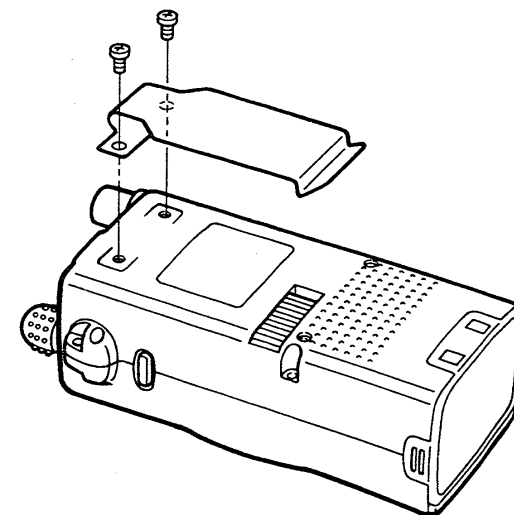

Battery pack removal

Slide the battery pack release button on the rear panel inward, then pull the battery pack downwards.

To insert the battery pack, insert it until hearing a click.

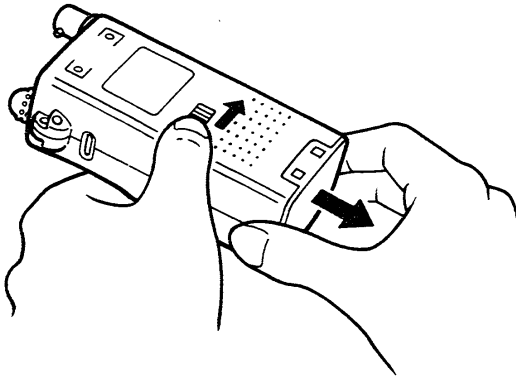

● **Be careful!** The transceiver has a battery stopper, therefore, exact insertion is necessary.

Battery case

An optional BP-110 BATTERY CASE is available for using the transceiver with dry cell or NiCd batteries.

To install the batteries, remove the battery case cover as shown in the diagram below.

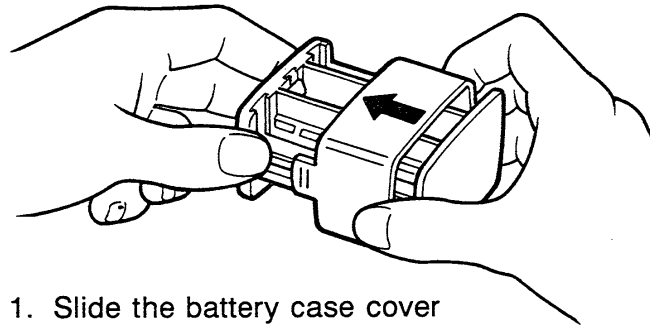

1. Slide the battery case cover to remove it.

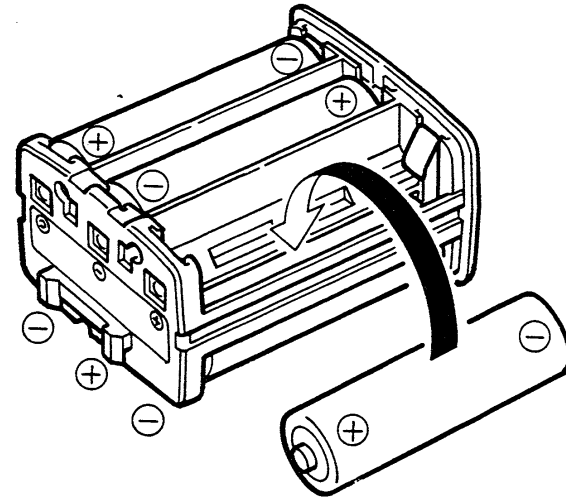

2. Install six AA (R6) type batteries. Make sure the polarities of the batteries match the indications on the battery case.

5 FREQUENCY SETTING

■ Pre-operation

1. Turn power ON.

Rotate the [PWR/VOL] control to turn power ON.

- Rotating the [PWR/VOL] control clockwise increases the audio level.

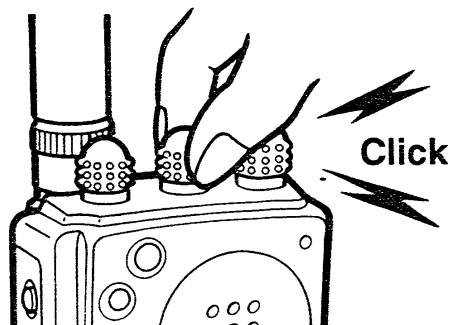

- To turn power OFF, rotate the [PWR/VOL] control max. counter-clockwise.

2. Select VFO mode.

Push [A CLR] once or twice to select VFO mode when the transceiver is not in VFO mode.

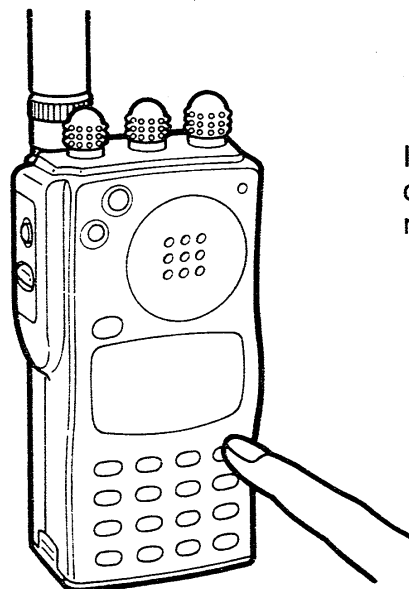

If “MR” or “L” is indicated here, the transceiver is not in VFO mode.

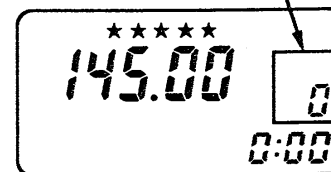

- When the lock function is activated, the keyboard and main dial cannot be used, and the mode cannot be changed. (p. 14)

What is VFO?

VFO mode is used for normal operations over the entire band and provides the operating frequency selection in the pre-programmed tuning steps.

VFO is an abbreviation for Variable Frequency Oscillator.

Lock function

To prevent accidental frequency changes and unnecessary function access, use the lock function.

- The main dial and keyboard are locked electronically.
- [PTT], [MONI], [H/L] and [LIGHT] can be used while the lock function is in use.

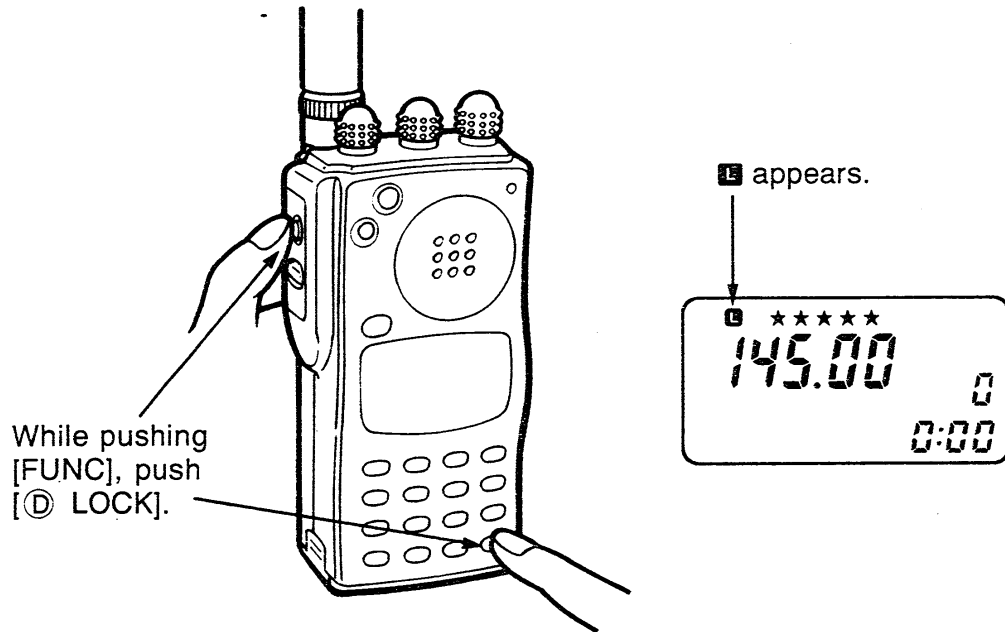

- To deactivate the function, while pushing [FUNC], push [LOCK] again.
- The PTT lock function is separately available. (pgs. 51, 53).

5 FREQUENCY SETTING

■ Using the main dial

1. Select VFO mode.

Push [A CLR] once or twice.

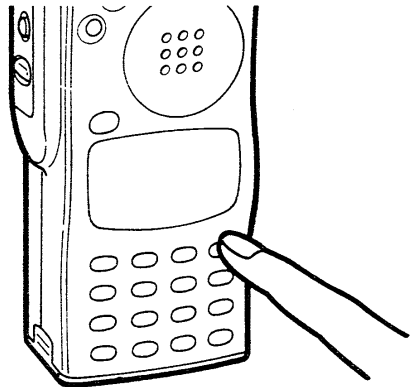

If "MR" or "Σ" is indicated here, the transceiver is not in VFO mode.

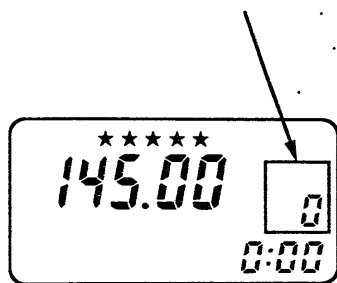

2. Set the frequency.

Rotate the main dial.

- The frequency changes according to the tuning step.
- See pgs. 51, 53 to change the tuning step.

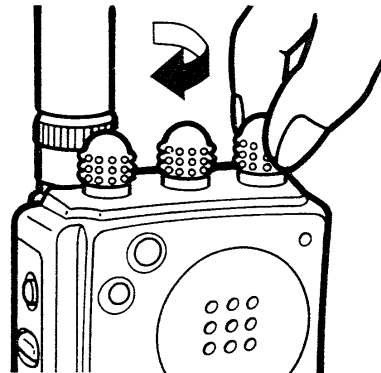

Clockwise rotation increases the frequency.

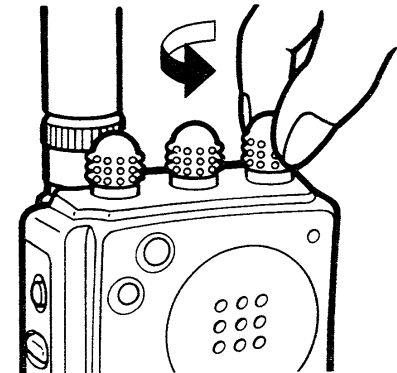
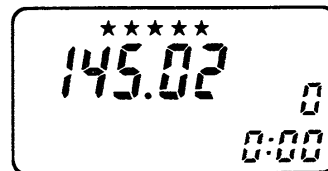

Counterclockwise rotation decreases the frequency.

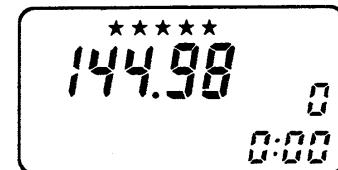

- For faster tuning, rotate the main dial while pushing [FUNC]. (p. 16)

■ Dial select step

In VFO mode, while pushing [FUNC], the main dial changes the frequency or memory channel number as illustration at far right.

This function is useful for quick frequency selection or memory channel selection in VFO mode.

Using dial select step

While pushing [FUNC], rotate the main dial.

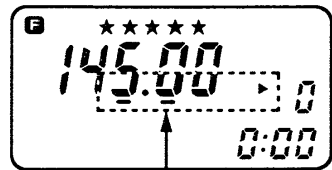
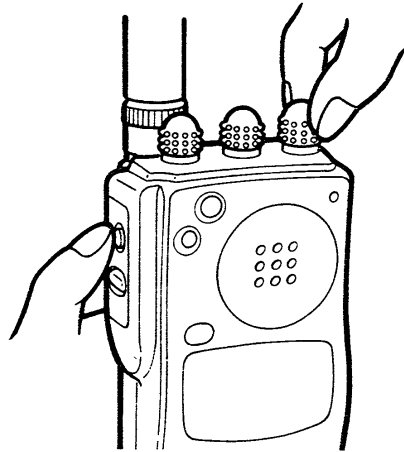

“-” or “▶” appears to indicate the selected digit or memory channel.

Setting the dial select step

While pushing [FUNC], push [MONI/DSEL] several times to change the dial select step.

- The bar underneath the number shows the digit that changes when the function is used.

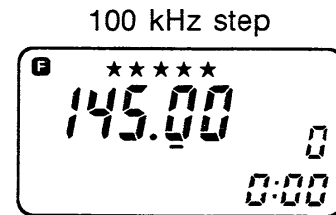
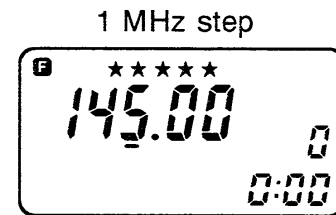
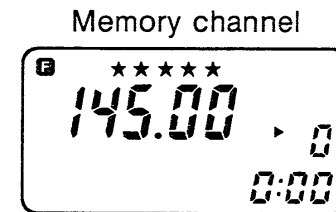
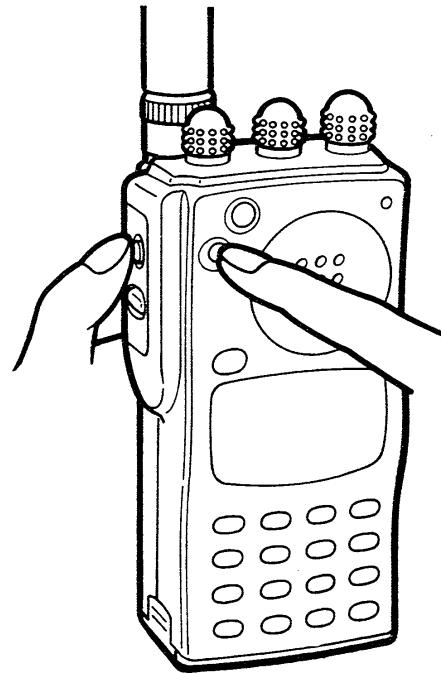

5 FREQUENCY SETTING

■ Using the numeral keys — Setting 145.100 MHz

1. Select VFO mode.

Push [**A** CLR] once or twice.

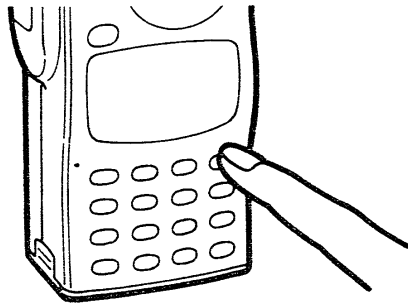

If “**MR**” or “**F**” is indicated here, the transceiver is not in VFO mode.

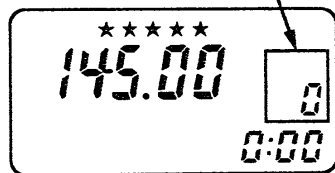

2. Enter from the MHz digit.

Push [**5**], [**1**], [**0**] and [**0**].

- A decimal point appears when frequency input is complete.

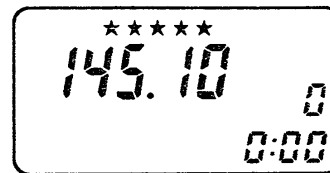
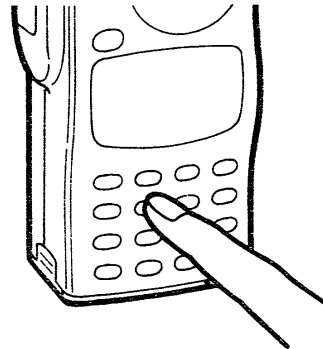

- [**0**] and [**5**] are acceptable for the 1 kHz digit (last digit); [**2**] and [**7**] are also acceptable depending on the 10 kHz digit.

When a wrong digit is entered:

Push [**A** CLR] to clear the entered digits.

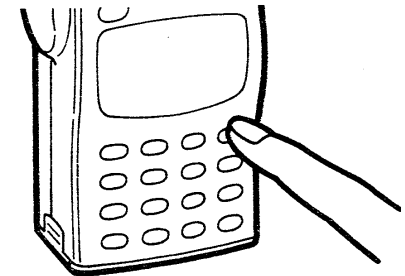

Push [**5**], [**1**], [**0**] and [**0**] again.

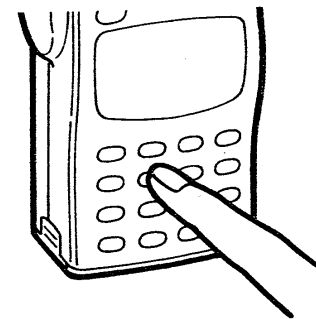

[IC-P2AT/ET EXAMPLE]: Setting the frequency to 145.360 MHz.

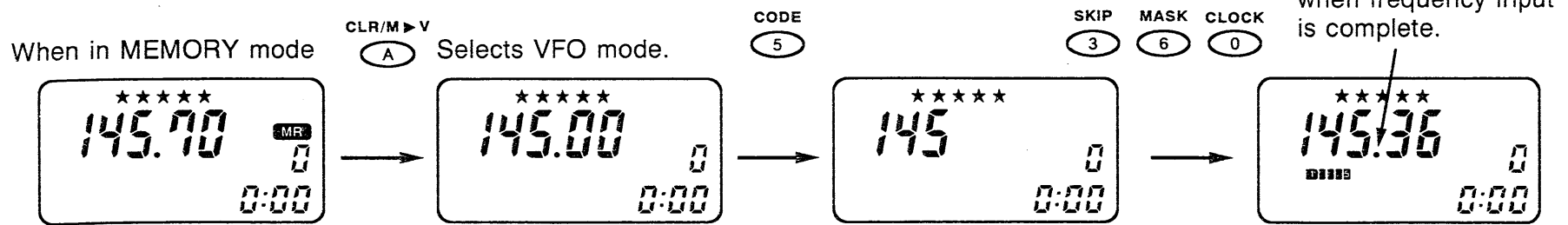

[IC-P2AT/ET EXAMPLE]: Setting the frequency to 145.7125 MHz.

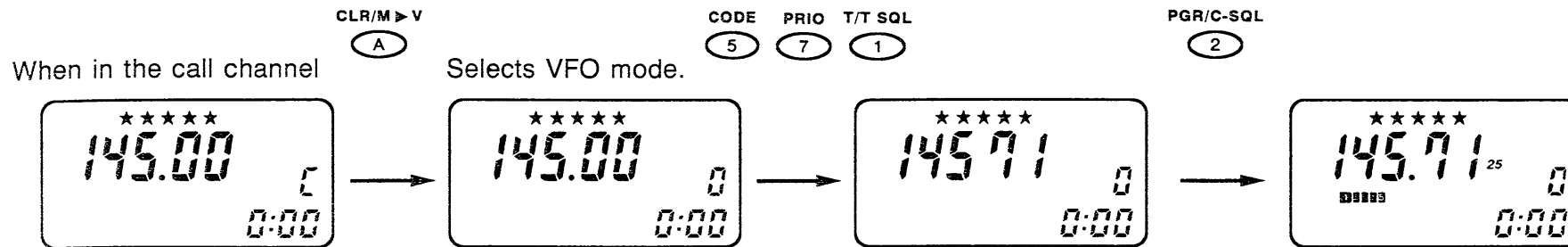

[IC-P4AT EXAMPLE]: Setting the frequency to 444.895 MHz.

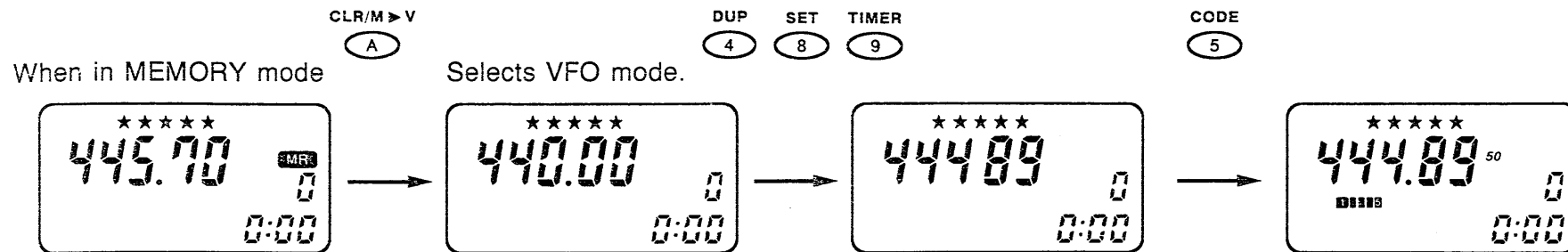

5 FREQUENCY SETTING

■ Using the Δ/∇ keys

1. Select VFO mode.

Push [$\text{\textcircled{A}}$ CLR] once or twice.

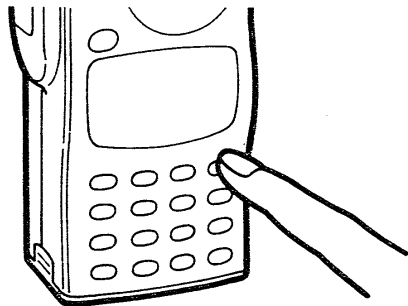

If “MR” or “ $\text{\textcircled{L}}$ ” is indicated here, the transceiver is not in VFO mode.

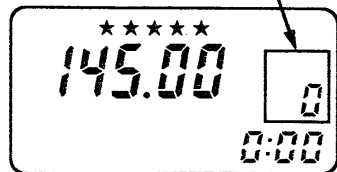

2. Set the frequency.

Push [$\text{\textcircled{*}}$ ∇] or [$\text{\textcircled{\#}}$ Δ].

- The frequency changes according to the tuning step.
- See pgs. 51, 53 to change the tuning step.

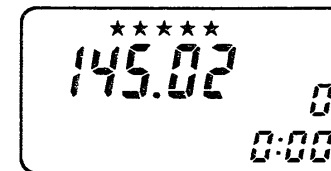
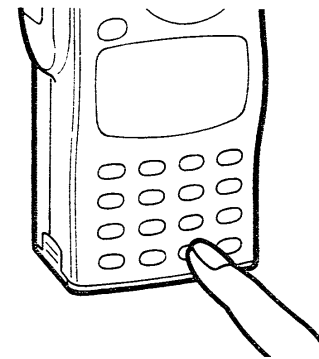
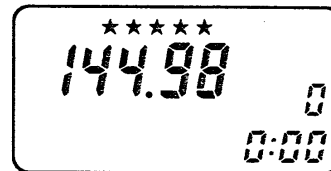
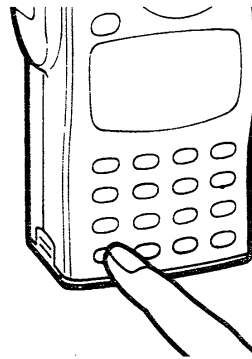

- When the optional pager or code squelch function is activated, frequency setting by the Δ/∇ keys is impossible. While pushing [FUNC], push [$\text{\textcircled{2}}$ PGR/C-SQL] several times until “PGR” or “C SQL” disappears to cancel the function.

When holding the key:

Holding the Δ/∇ keys for more than 0.5 sec. will activate full scan.

Push [$\text{\textcircled{*}}$ ∇] or [$\text{\textcircled{\#}}$ Δ] again to cancel the scan.

Pushing [$\text{\textcircled{A}}$ CLR] also stops the scan.

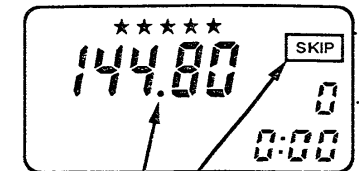

The decimal point and “SKIP” blink while scanning.

■ Display lighting

The transceiver has display and keyboard backlights for night operation. Normally, lighting continues for 5 sec. only, but continuous lighting is also possible.

Activate lighting for 5 sec.

Push [LIGHT].

- Lighting activates for 5 sec. and then automatically turns OFF.

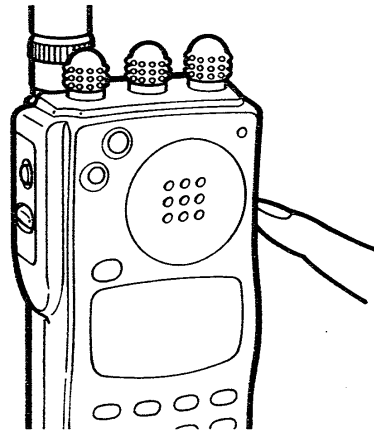

- Lighting remains activated while you operate the main dial, some keys or switches, except [PTT].

Activate continuous lighting.

While pushing [FUNC], push [LIGHT].

- To turn lighting OFF, push [LIGHT].

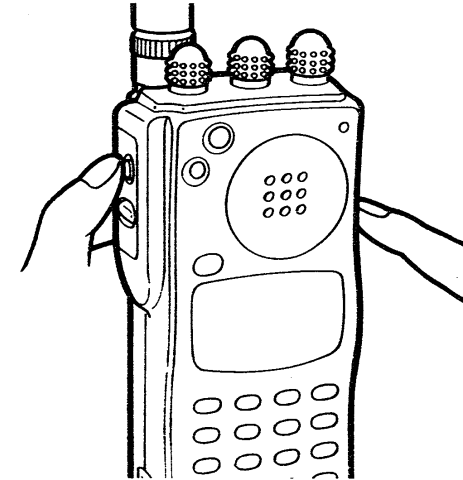

- Continuous lighting remains activated even if the power is turned OFF and ON again.

6

RECEIVING

■ Receiving — Receiving 145.100 MHz

1. Adjust audio level.

Rotate [SQL] to max. counterclockwise to open the squelch and set [PWR/VOL] to the desired audio level.

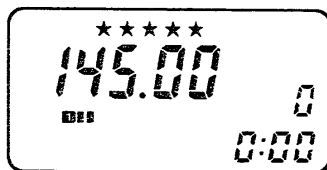
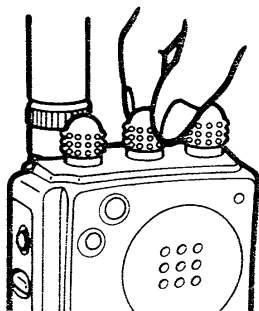

2. Set squelch level.

Rotate [SQL] clockwise until noise disappears.

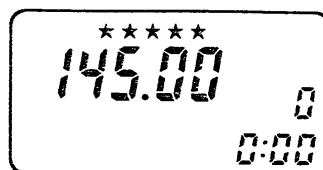
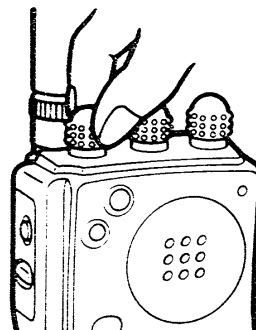

- When [SQL] is set too "tight" (extremely clockwise), squelch may not open for weak signals. In this case, set the squelch to a "loose" (less clockwise) position, or push and hold [MONI/DSEL].

3. Set the frequency.

Set the operating frequency using the main dial or keyboard. (See pgs. 15 ~ 20 for details.)

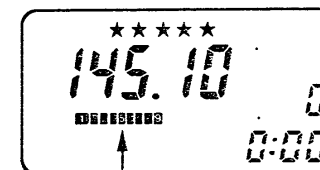
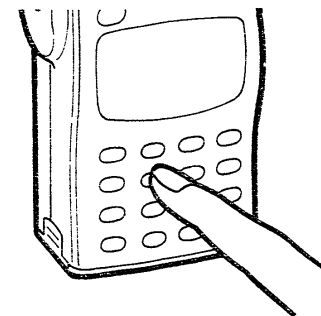

When receiving a signal

- When an optional tone or code squelch is turned ON, push [MONI/DSEL] to open the squelch.

■ Transmitting

Transmitting a signal

Push and hold [PTT] to transmit; release to receive.

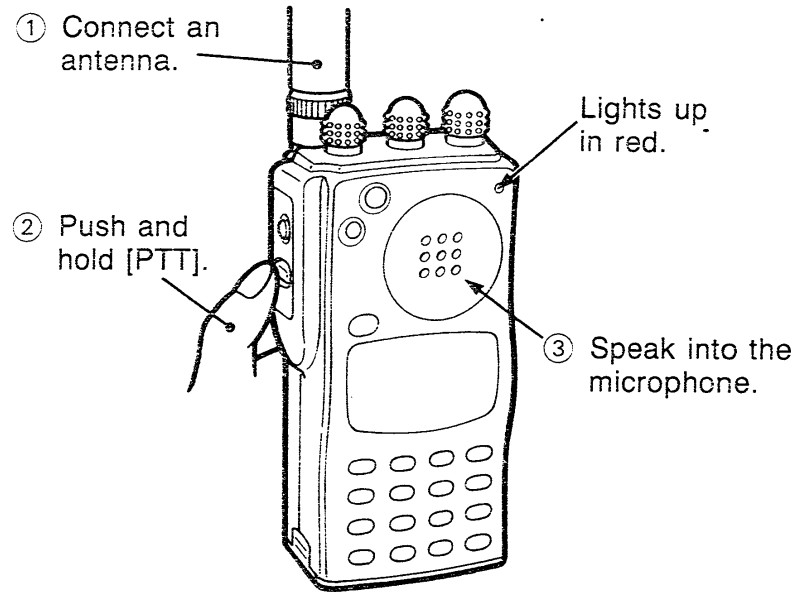

- To prevent interference, listen on the frequency before transmitting using [MONI/DSEL].
- To prevent accidental transmission, the PTT lock function is available. (See p. 53 for details.)
- Holding the transceiver too closely to your mouth or speaking too loudly may distort the signal.

■ Selecting output power

Select output power.

SELECTING HIGH OR LOW

Push [H/L/DTMF].

- "LOW" appears when low power is selected.

SETTING LOW OUTPUT LEVELS

While pushing [H/L/DTMF], rotate the main dial to set the desired low output level.

- The S/R/F indicator shows the selected level as below.

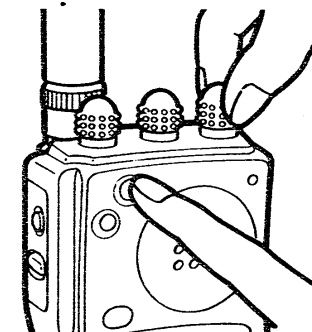
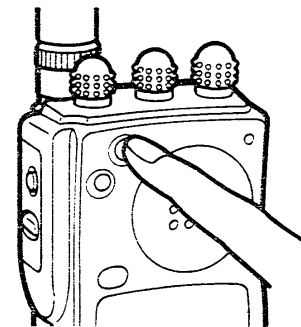

POWER SELECTION	S/R/F INDICATOR	OUTPUT POWER	
		with 13.8 V	with 7.2 V
HIGH		5.0 W	1.5 W
LOW 3	LOW	3.5 W	1.5 W
LOW 2	LOW	1.5 W	1.5 W
LOW 1	LOW	0.5 W	0.5 W

8

MEMORY MODE

■ General description

The transceiver has 100 memory channels for storage of often-used frequencies. You can program the following data into a memory channel.

- Operating frequency
- Duplex direction (DUP or –DUP)
- Offset frequency*1
- Subaudible tone frequency*1*2
- Tone encoder ON/OFF*2
- Tone squelch ON/OFF*3
- Skip information (p. 35)

*1Memory channels 0~9 can be independently programmed.

*2An optional UT-50 TONE SQUELCH UNIT or UT-51 TONE ENCODER UNIT is necessary.

*3An optional UT-50 TONE SQUELCH UNIT is necessary.

When first applying power or after resetting, memory channels 10~99 are masked.

■ Selecting MEMORY mode

Select MEMORY mode.

Push [B MR].

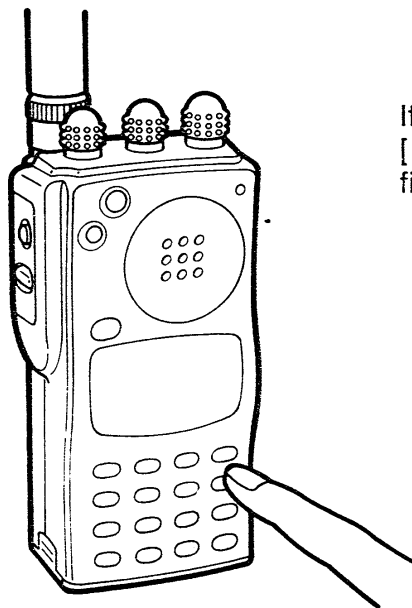

If “” is indicated here, push [A CLR] to exit the call channel at first.

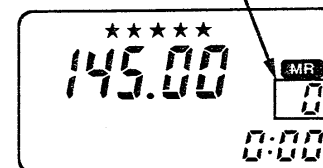

- To return to VFO mode, push [A CLR].
- When the lock function is activated, the keyboard and main dial cannot be used, and the mode cannot be changed. (p. 14)

■ Selecting a memory channel

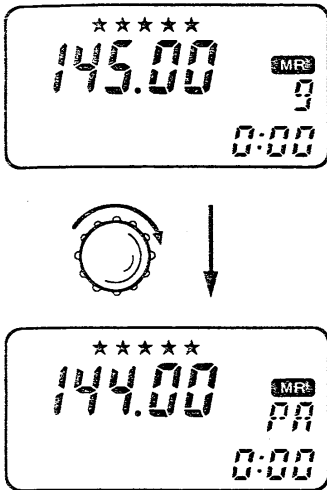
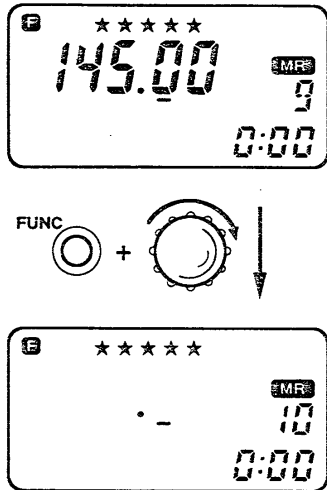
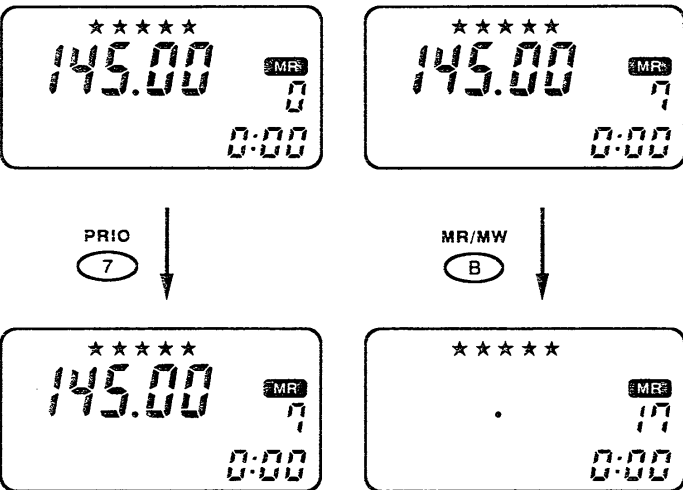
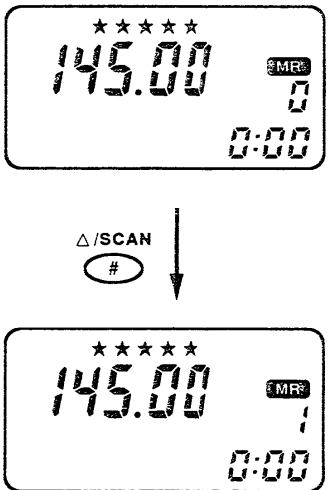
Using main dial	[FUNC] + main dial	Using keyboard	Δ/∇ keys
<p>Rotate the main dial.</p>  <ul style="list-style-type: none"> ● Masked channels cannot be selected. 	<p>While pushing [FUNC], rotate the main dial.</p>  <ul style="list-style-type: none"> ● All memory channels can be selected. 	<p>Push a numeral key to enter the first digit into the memory channel.</p> <p>Push [ⓑ MR] to change the memory channel in units of 10.</p>  <ul style="list-style-type: none"> ● When "PA" or "PB" has been selected, use another method to select the channel. ● All memory channels except "PA" or "PB" can be selected. 	<p>Push [⊛ ∇] or [⊚ Δ] to change the memory channel.</p>  <ul style="list-style-type: none"> ● Masked channels cannot be selected.

8 MEMORY MODE

■ Programming a memory channel — Programming 145.320 MHz into ch 7

1. Select a channel.

Push [**B** MR] to select MEMORY mode.

“MR” appears.

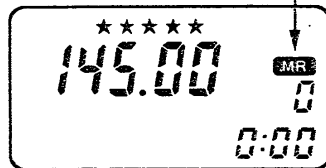

Rotate the main dial to select a memory channel for programming.

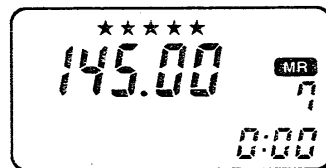

- The dial select step is useful to select a memory channel in VFO mode. (p. 16)

2. Set a frequency.

Push [**A** CLR] to select VFO mode; then, push [**5**], [**3**], [**2**] and [**0**].

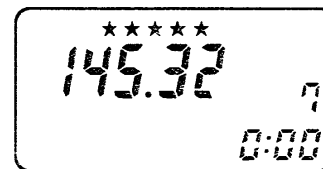
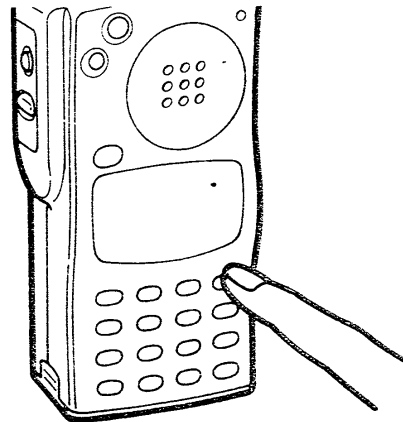

- Set other data (e.g. duplex information), if desired.

3. Program into the channel.

While pushing [FUNC], push and hold [**B** MW] for 2 sec.

- The transceiver emits 3 beeps.

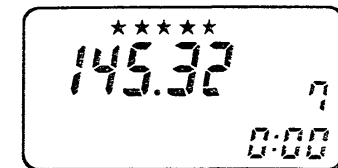
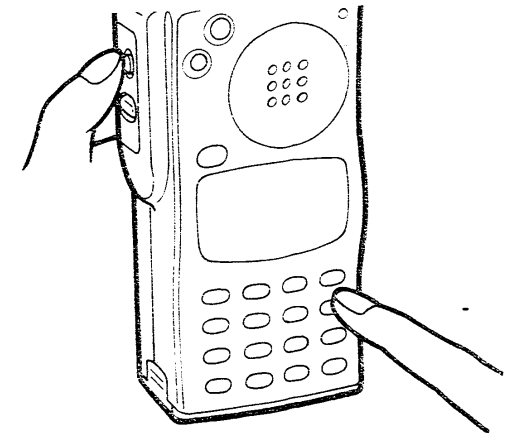

■ Transferring memory contents

This function transfers the memory channel contents into the VFO along with some operating conditions (e.g. duplex information).

This function is useful when searching for signals around the displayed memory channel frequency and for recalling the offset frequency, subaudible tone frequency, etc. which are programmed in memory channels 0~9.

1. Select MEMORY mode.

Push [Ⓑ MR] to select MEMORY mode.

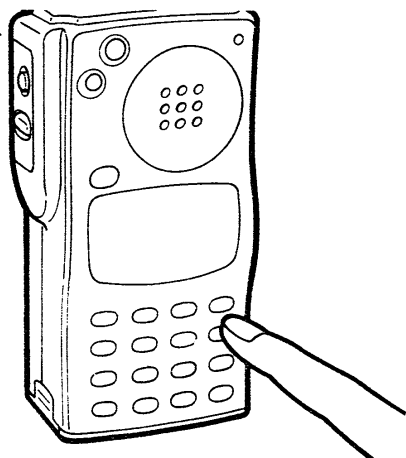

"MR" appears.

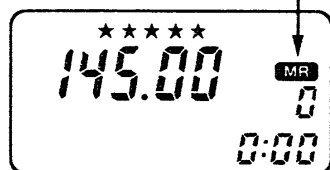

2. Select the channel.

Rotate the main dial or use the keyboard. (p. 24)

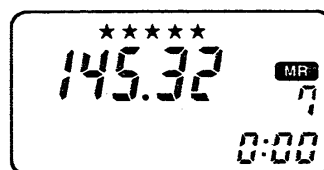
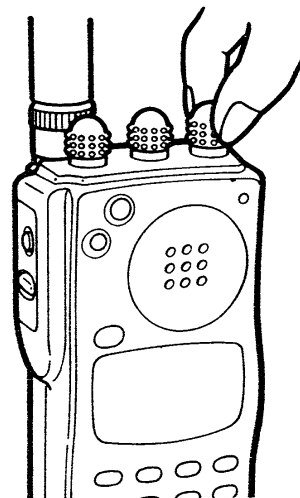

3. Transfer the contents.

While pushing [FUNC], push and hold [Ⓐ M▶V] for 2 sec.

- The transceiver emits 3 beeps.

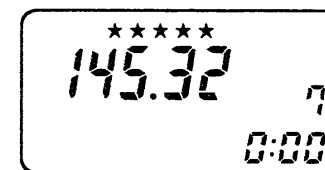
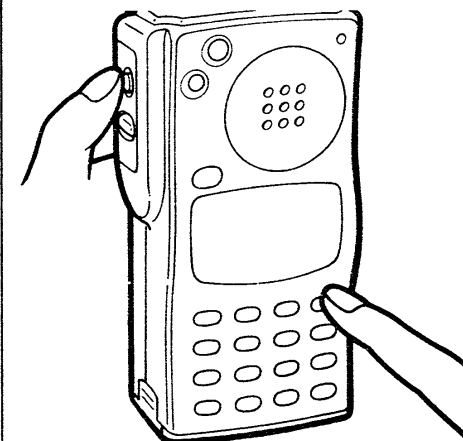

- VFO mode is selected.

8 MEMORY MODE

■ Masking a memory channel

★★★★ At least 4 stars are necessary.

1. Select the channel.

Push [Ⓑ MR] to select MEMORY mode.

“MR” appears.



Rotate the main dial to select the desired channel.

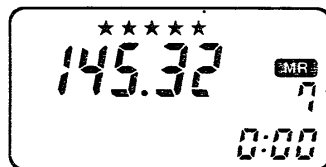

2. Mask the channel.

While pushing [FUNC], push [Ⓔ MASK].

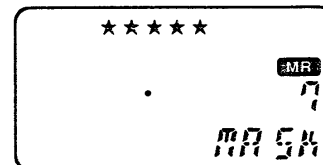
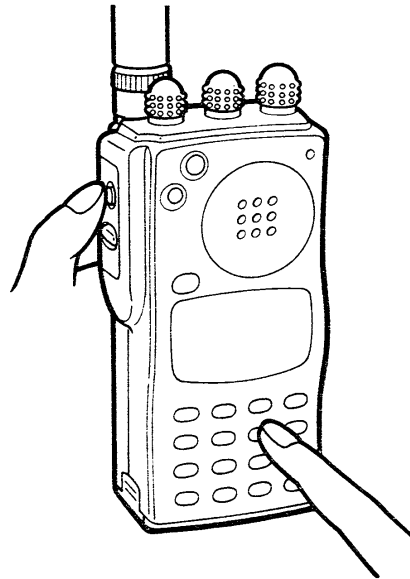

● Memory channel 0 cannot be masked.

3. Recall the channel.

Push [Ⓑ MR] to select MEMORY mode. While pushing [FUNC], rotate the main dial to select the channel to be recalled.

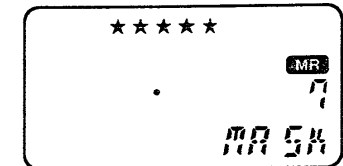

While pushing [FUNC], push [Ⓔ MASK] to recall the frequency.

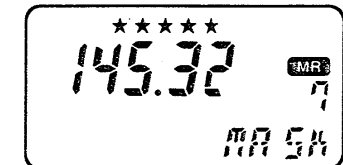

■ General description

A one-touch-access call channel is provided for operation on your most-often-used frequency. This call channel is separate from the memory channels.

You can program the following data into the call channel.

- Operating frequency
- Duplex direction (DUP or –DUP)
- Offset frequency
- Subaudible tone frequency*1
- Tone encoder ON/OFF*1
- Tone squelch ON/OFF*2

*1 An optional UT-50 TONE SQUELCH UNIT or UT-51 TONE ENCODER UNIT is necessary.

*2 An optional UT-50 TONE SQUELCH UNIT is necessary.

1. Call up the call channel.

Push [D CALL].

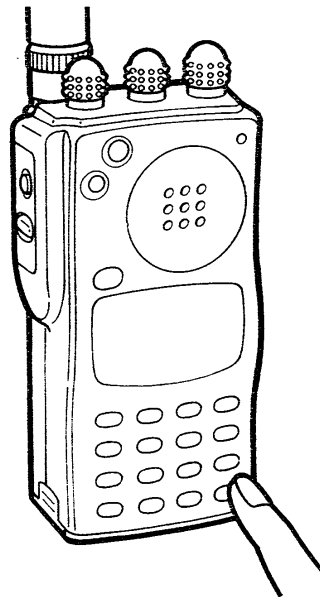

“**C**” appears.

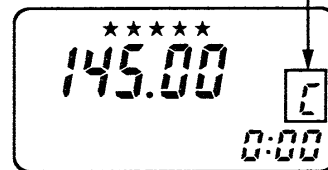

2. Return to the previous mode.

Push [A CLR] or push [D CALL].

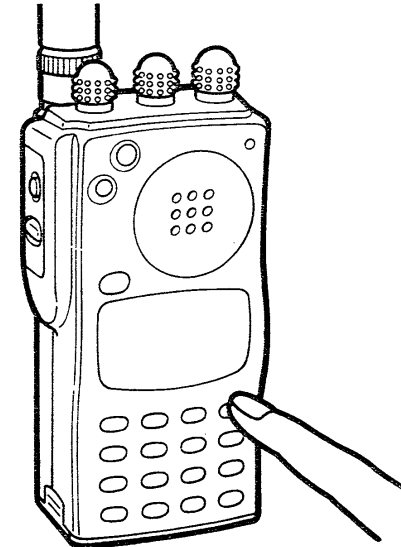

9 CALL CHANNEL

■ Programming the call channel — Programming 145.500 MHz

1. Set a frequency.

Push [A CLR] to select VFO mode; then, push [5], [5], [0] and [0].

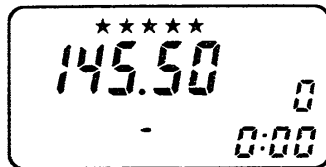
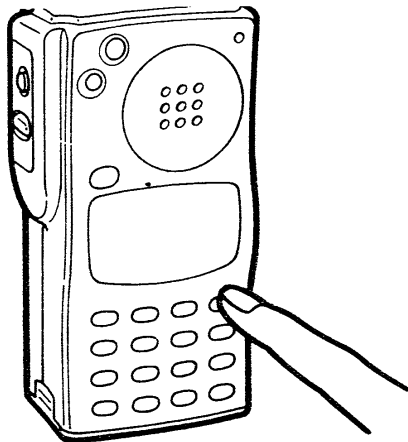

- Set other data (e.g. duplex information), if desired.

2. Select the call channel.

Push [D CALL] to select the call channel.

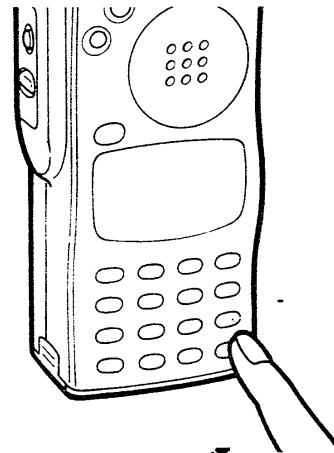

" [] " appears.

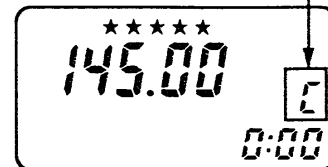

3. Program into the call channel.

While pushing [FUNC], push and hold [B MW] for 2 sec.

- The transceiver emits 3 beeps.

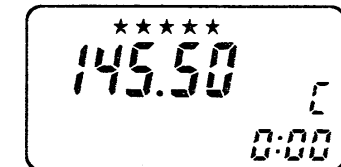
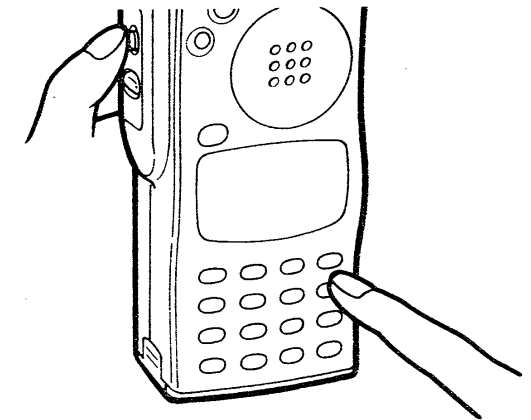

■ Transferring call channel contents

This function transfers the call channel contents into the VFO along with some operating conditions (e.g. duplex information).

This function is useful when searching for signals around the call channel frequency and for recalling the offset frequency, subaudible tone frequency, etc. which are programmed in the call channel.

1. Select the call channel.

Push [CALL] to select the call channel.

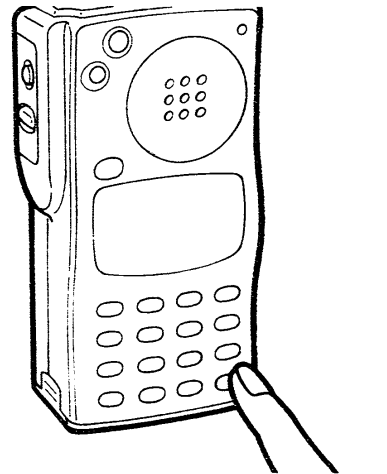

"[CALL]" appears.

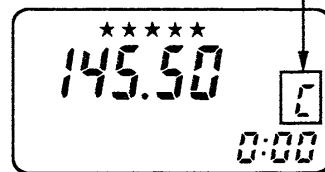

2. Transfer the contents.

While pushing [FUNC], push and hold [M/V] for 2 sec.

- The transceiver emits 3 beeps.

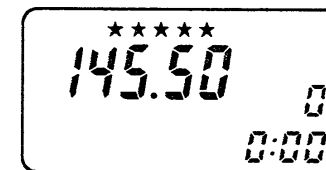
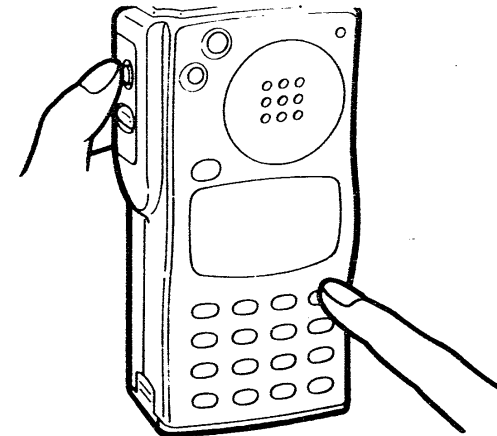

- The frequency and other data remain, yet VFO mode is selected.

10 SCAN OPERATION

■ Scan types

The transceiver has 3 scan types with a skip function and 3 resume conditions to suit your needs.

Scan does not function when either the priority watch, optional pager or code squelch is activated.

FULL SCAN

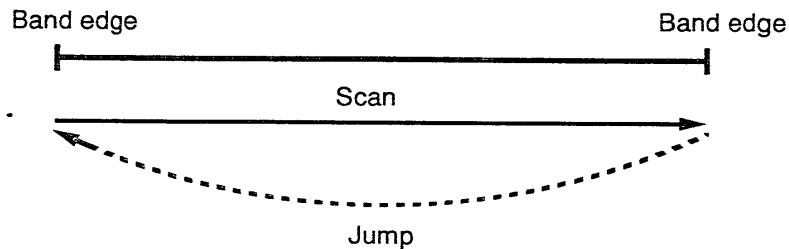

Repeatedly scans all frequencies over the entire band.

MEMORY SCAN

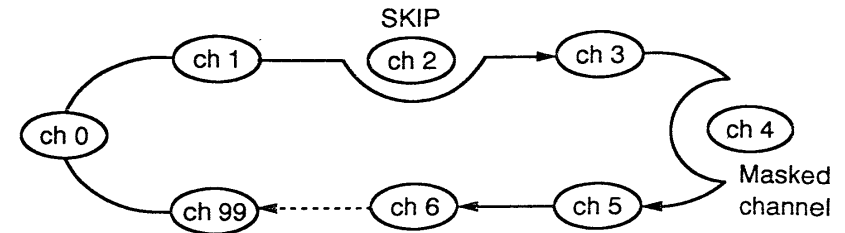

Repeatedly scans memory channels except skip channels and masked channels.

PROGRAMMED SCAN

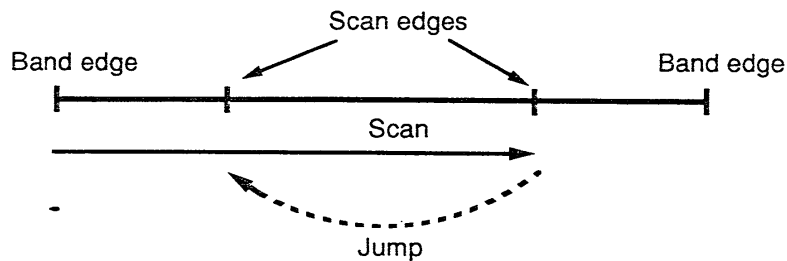

Repeatedly scans between two user-programmed frequencies.

FREQUENCY SKIP FUNCTION

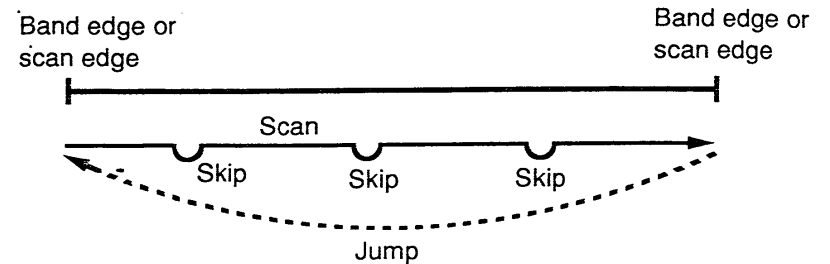

Skips unwanted frequencies that inconveniently stop scanning.

■ Full scan

The transceiver scans all frequencies over the entire band in VFO mode repeatedly.

Select the tuning step (p. 53) and scan resume condition (p. 55), if desired.

The frequency skip function can be used. (p. 35)

USING MAIN DIAL

While scanning, rotating the main dial changes the scanning direction or skips a paused frequency.

1. Select VFO mode. Set squelch level.

Push [A CLR].

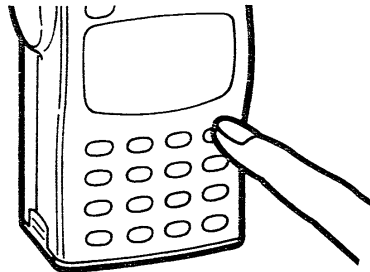

Turn [SQL] until noise disappears.

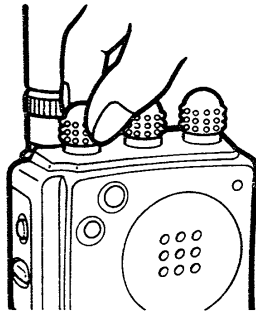

2. Start full scan.

Push and hold [* ∇] or [# Δ].

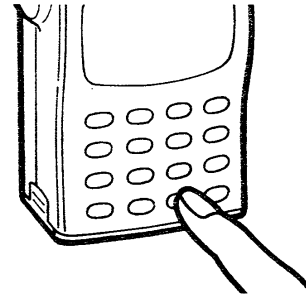

"SKIP" blinks.

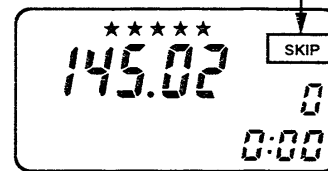

- When receiving a signal, scan resumes in one of the following ways.

(pgs. 51, 55)

- after pausing 10 sec.
- after pausing 5 sec.
- after the signal disappears.

3. Stop the scan.

Push [* ∇] or [# Δ].

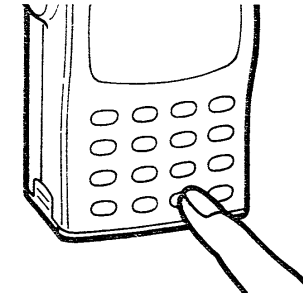

"SKIP" disappears.

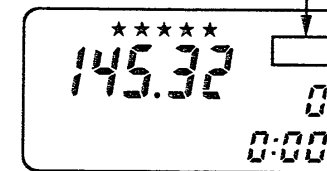

- Pushing [A CLR] also stops the scan.

10 SCAN OPERATION

■ Programming scan edges — Programming 145.000 MHz and 145.500 MHz

Scan edge frequencies are stored in memory channels "PA" and "PB."

Programmed scan repeatedly scans between these two frequencies.

1. Select memory channel "PA."

Push [B MR].

"MR" appears.

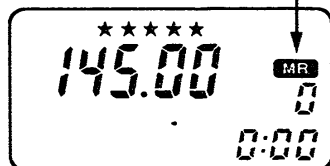

Rotate the main dial or push [* ▽] or [# △] to select memory channel "PA."

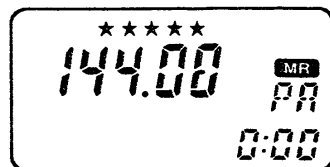

2. Program a scan edge.

Push [A CLR] to select VFO mode; then, push [5], [0], [0] and [0].

While pushing [FUNC], push and hold [B MW] for 2 sec.

- The transceiver emits 3 beeps.

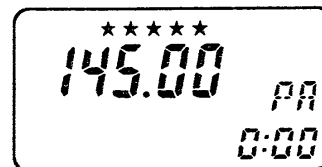
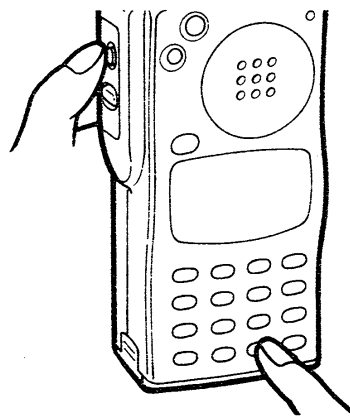

3. Program the other scan edge.

Push [B MR] and then push [# △] to select memory channel "PB."

Push [A CLR] to select VFO mode; then, push [5], [5], [0] and [0].

While pushing [FUNC], push and hold [B MW] for 2 sec.

- The transceiver emits 3 beeps.

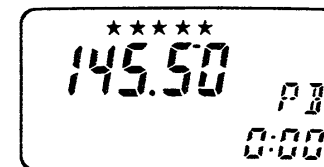

■ Programmed scan

Program the scan edge frequencies into memory channels "PA" and "PB" before using programmed scan.

Select the tuning step (p. 53) and scan resume condition (p. 55), if desired.

The frequency skip function can be used. (p. 35).

USING MAIN DIAL

While scanning, rotating the main dial changes the scanning direction or skips a paused frequency.

1. Select VFO mode. Set squelch level.

Push [A CLR].

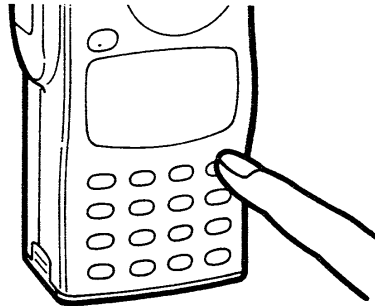

Turn [SQL] until noise disappears.

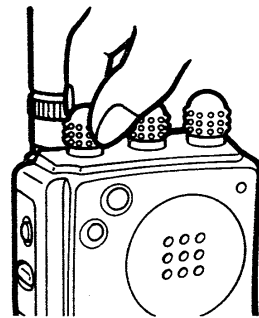

2. Start programmed scan.

While pushing [FUNC], push and hold [\ast ∇] or [$\#$ Δ].

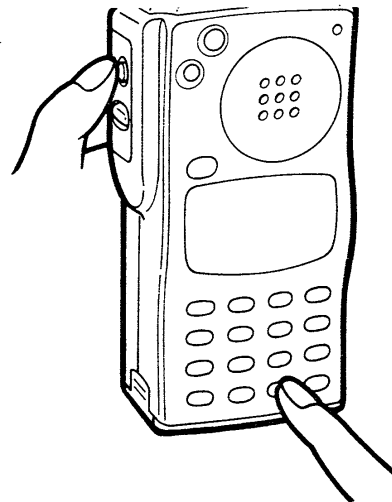

- When receiving a signal, scan resumes in one of the following ways. (pgs. 51, 55)
 - after pausing 10 sec.
 - after pausing 5 sec.
 - after the signal disappears.

3. Stop the scan.

Push [\ast ∇] or [$\#$ Δ].

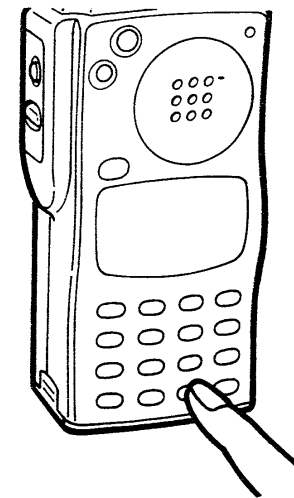

- Pushing [A CLR] also stops the scan.

10 SCAN OPERATION

■ Frequency skip function

This function allows the scan to skip unwanted frequencies that inconveniently stop scanning during full or programmed scan.

Frequencies can be programmed when full or programmed scan is pausing.

You can also program skip frequencies before starting the scan. Program the frequencies into memory channels with skip information. (p. 36)

1. Select VFO mode.

Push [A CLR] to select VFO mode.

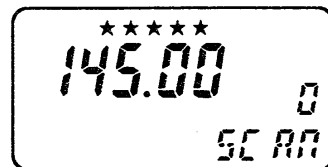
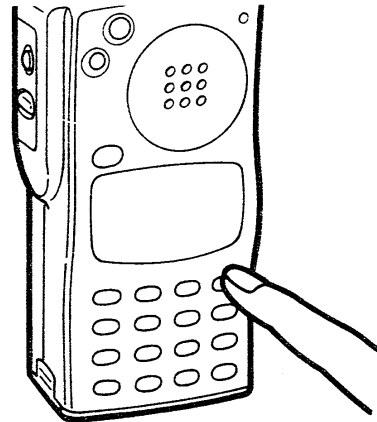

2. Start a scan.

Push and hold [* ∇] or [# Δ] to start full scan.

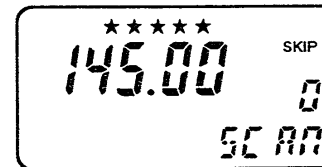
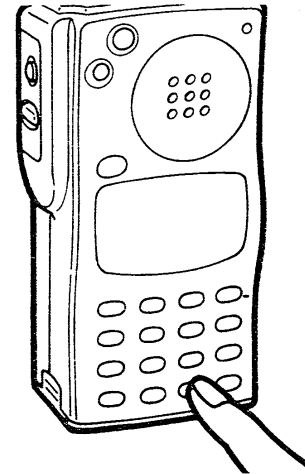

- While pushing [FUNC], push [* ∇] or [# Δ] to start programmed scan.

3. Program skip freq.

While pushing [FUNC], push [B MW] for 2 sec.

- The transceiver emits 3 beeps and the scan resumes.

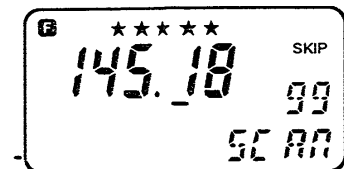
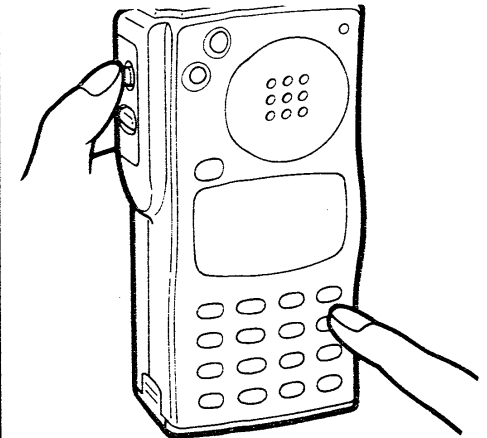

- Masked memory channels 99 ~ 10 are used in reverse sequence.

■ Setting and cancelling skip information

★★★★ At least 4 stars are necessary.

1. Select memory channel.

Push [Ⓑ MR].

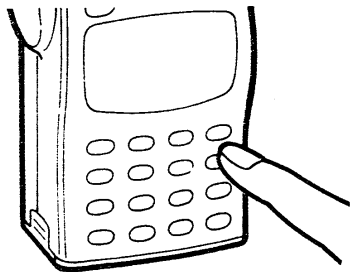

Rotate the main dial to select the desired channel.

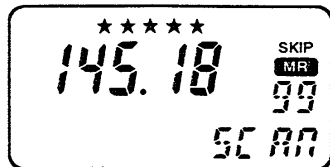
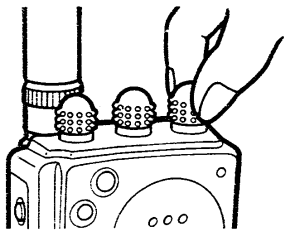

2. Cancel or set the skip information.

While pushing [FUNC], push [Ⓒ SKIP].

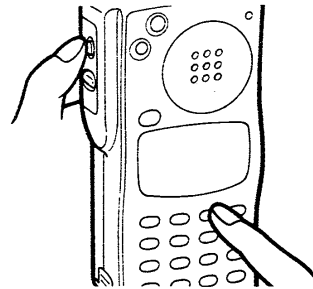

Skip information is cancelled in memory channel 99.

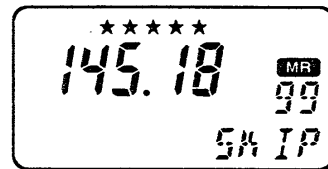

Skip information is set in memory channel 99.

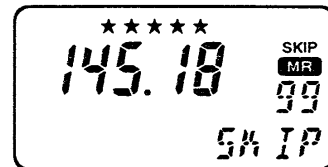

Using the mask function to cancel

While pushing [FUNC], push [Ⓔ MASK] to mask the memory channel with skip information.

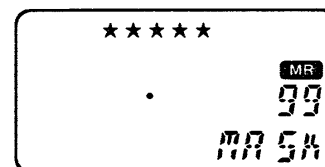
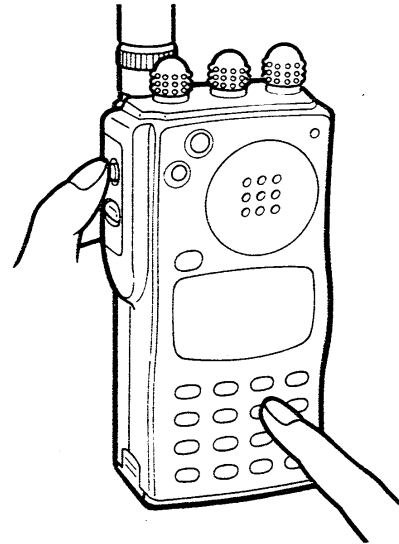

Frequency skip function on/off

The frequency skip function can be turned OFF in SET mode. See pgs. 51 and 54 for details.

In this case, the frequencies will not be skipped even if skip information is programmed and "SKIP" will not blink while scanning.

Frequency skip function is turned OFF.

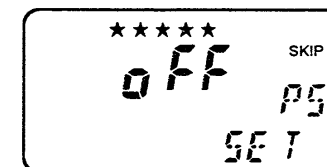

10 SCAN OPERATION

■ Memory scan

Memory scan repeatedly scans all memory channels, except masked channels and skip memory channels in sequence.

Select the scan resume condition (pgs. 51, 55), if desired.

The skip function can be used. (p. 38)

USING MAIN DIAL

While scanning, rotating the main dial changes the scanning direction or skips a paused channel.

1. Select MEMORY mode. Set squelch level.

Push [**B** MR].

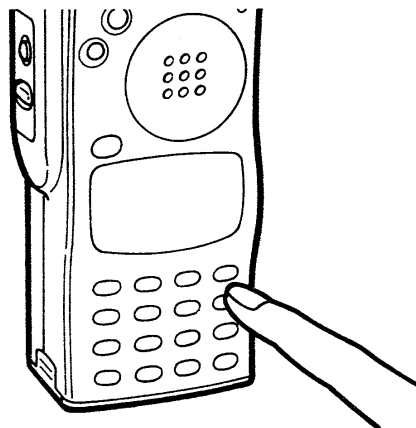

Turn [SQL] until noise disappears.

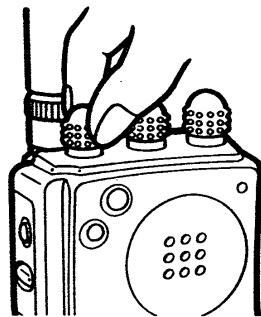

2. Start memory scan.

Push and hold [***** ▽] or [**#** △].

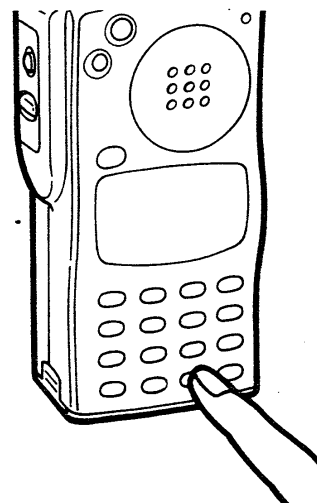

- When receiving a signal, scan resumes in one of the following ways. (pgs. 51, 55)
 - after pausing 10 sec.
 - after pausing 5 sec.
 - after the signal disappears.

3. Stop the scan.

Push [***** ▽] or [**#** △].

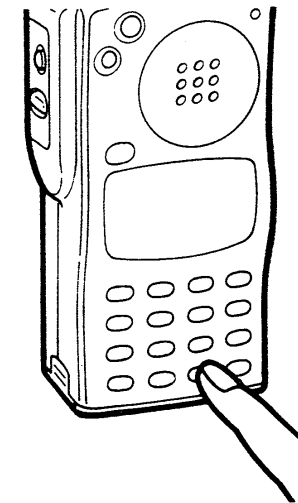

- Pushing [**A** CLR] also stops the scan.

■ Programming a skip memory channel

★★★★ At least 4 stars are necessary.

This function allows the scan to skip unwanted channels that inconveniently stop scanning during memory scan.

1. Program a skip memory channel.

Push [**B** MR]; then, rotate the main dial, or push [***** ▽] or [**#** △] to select the memory channel.

While pushing [FUNC], push [**3** SKIP].

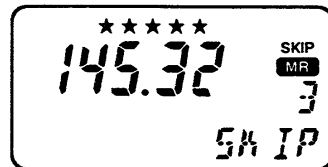
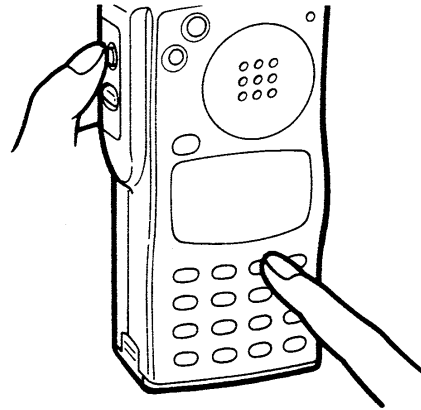

2. Cancel a skip memory channel.

Push [**B** MR]; then, rotate the main dial or push [***** ▽] or [**#** △] to select the memory channel.

While pushing [FUNC], push [**3** SKIP].

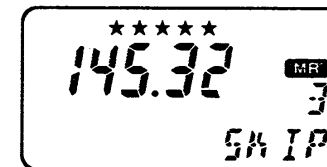
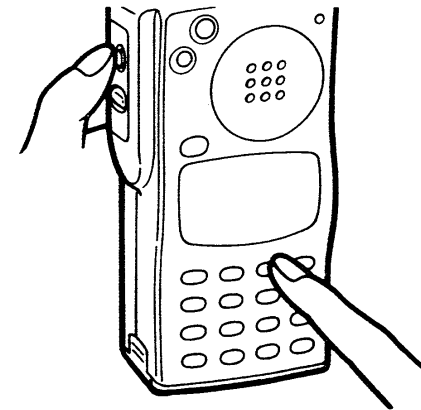

11 REPEATER OPERATION

■ General description

A repeater receives signals and retransmits them at a different frequency. When using a repeater, your signal can therefore reach a long distance.

Before using a repeater, be sure the offset frequency is matched with the repeater shift frequency. See pgs. 51 and 52 for setting.

To use a subaudible tone, an optional UT-50 TONE SQUELCH UNIT or UT-51 TONE ENCODER UNIT is necessary.

A 1750 Hz tone call is equipped with the IC-P2ET and IC-P4ET.

Push and hold [MONI/DSEL] to check whether the other stations's signal on the repeater input frequency can be directly received or not.

■ Operation

1. Set receive frequency.

Push [Ⓐ CLR]; then, set the receive frequency (repeater output frequency) using the main dial or the keyboard.

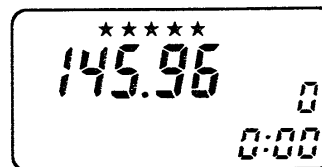
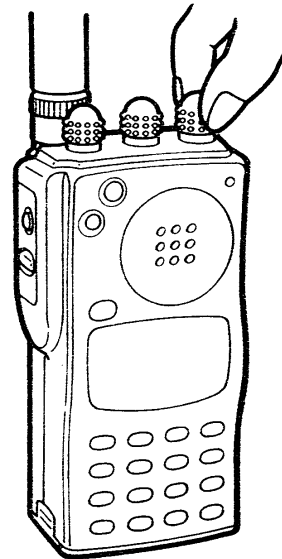

2. Select duplex direction.

While pushing [FUNC], push [④ DUP] to select -duplex and push it again for +duplex.

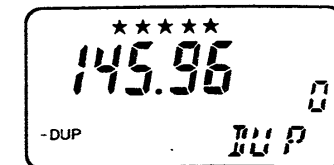
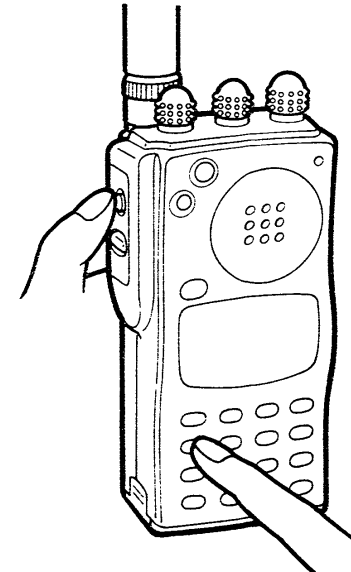

★★ At least 2 stars are necessary.

3. Access a repeater.

SUBAUDIBLE TONE

While pushing [FUNC], push [① T/T SQL] to turn ON the subaudible tone encoder. (Optional; see pgs. 50 ~ 51 for setting the subaudible tone frequency.)

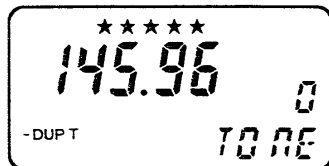

DTMF TONES

While pushing [PTT], push the desired digit keys to transmit DTMF tones.

- 16 DTMF memory channels are equipped in the transceiver. (p. 47)

1750 Hz TONE (Europe version only)

While pushing [LIGHT], push [PTT] to transmit a 1750 Hz tone.

- Quickly pushing [PTT] and then briefly holding [PTT] down a second time also transmits a 1750 Hz tone.

4. Make communication.

Operate the transceiver as in normal communication.

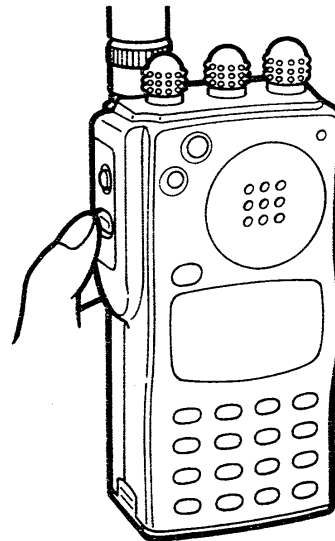

- If "o.FF" appears, confirm the offset frequency and duplex direction.

5. Return to simplex

While pushing [FUNC], push [④ DUP] until "- DUP" or "DUP" disappears.

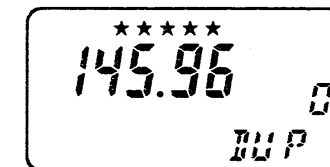
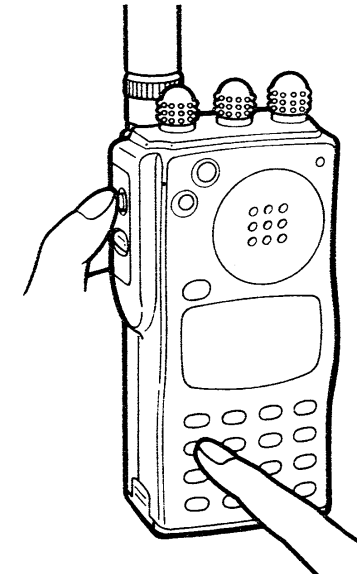

12 MODE CONSTRUCTION

■ Mode types

The transceiver has 6 different modes and 1 call channel for versatile, multi-function operations.

VFO MODE

(frequency setting) (p. 13)

Used for frequency setting and normal operations over the entire band.

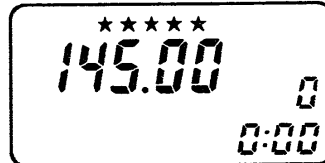

MEMORY MODE (p. 23)

Used for operating the transceiver using memory channel contents. 100 memory channels are available for programming.

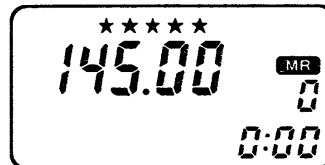

CALL CHANNEL (p. 28)

Used for operating the transceiver on a programmed call channel.



SET MODE (p. 50)

Used for programming infrequently used settings.

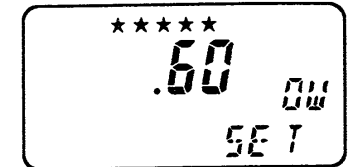

DTMF MEMORY MODE (p. 47)

Used for programming DTMF codes. 16 DTMF memory channels with up to 15 digits of programming capability are available.

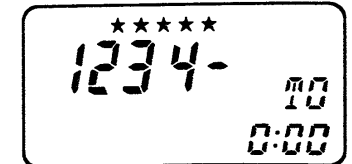

AI SELECTION MODE (p. 58)

Used for selecting a function of the [AI] key.



TIMER MODE (p. 59)

Used for setting the power-on timer, power-off timer and auto power-off function.



Mode arrangement chart

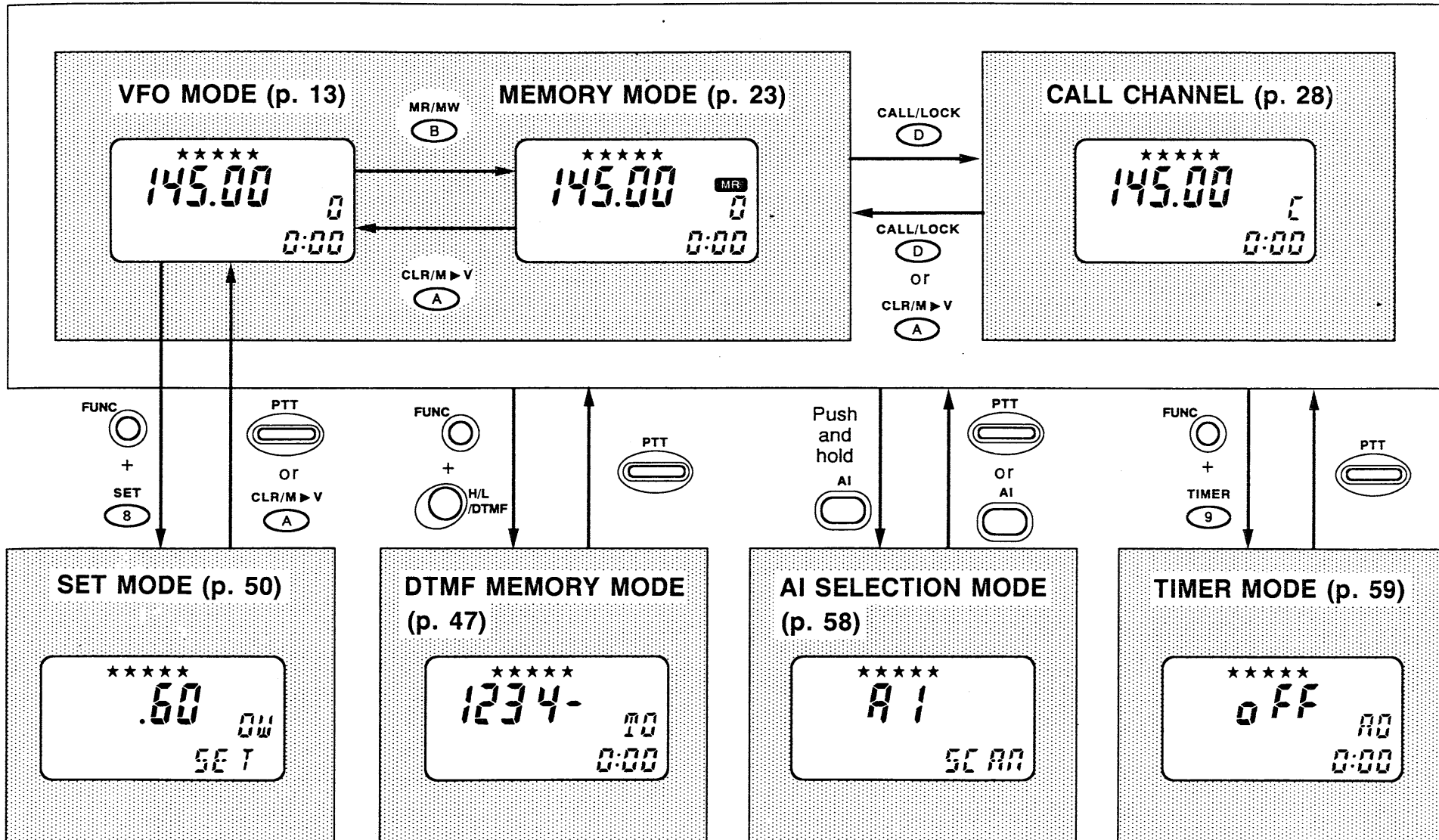

ADVANCED

13 PRIORITY WATCH

Priority watch types

The priority watch checks for signal in a memory or call channel every 5 sec. while operating on a VFO frequency. The transceiver has 3 priority watch types to suit your needs.

Transmitting can be performed at the VFO frequency even if the priority watch activates.

When receiving a signal, priority watch pauses for 15 sec. (if the signal disappears within 15 sec. the watch resumes).

★★★ At least 3 stars are necessary.

MEMORY SCAN WATCH

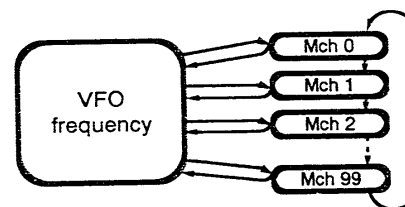

While operating on a VFO frequency, priority watch checks for signals in each memory channel in sequence.

- For shorter scanning intervals, program unwanted channels as skip memory channels. See p. 38 for details.

MEMORY CHANNEL WATCH

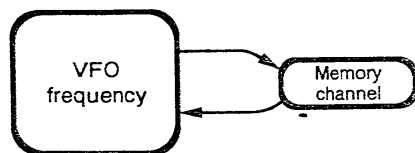

While operating on a VFO frequency, priority watch checks for signals in a selected memory channel every 5 sec.

- When the selected memory channel is masked (hidden), the watch does not start.
- Skip memory channels can be selected.

CALL CHANNEL WATCH

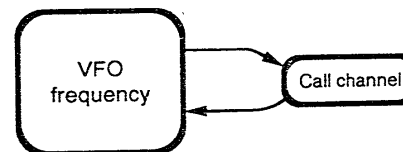

While operating on a VFO frequency, priority watch checks for a signal on the call channel every 5 sec.

Memory channel watch

1. Set VFO frequency. Set squelch level.

Push [A CLR]; then, rotate the main dial to set the operating frequency.

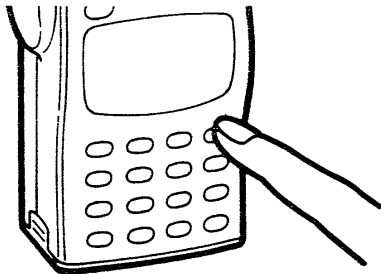

Turn [SQL] until noise disappears.

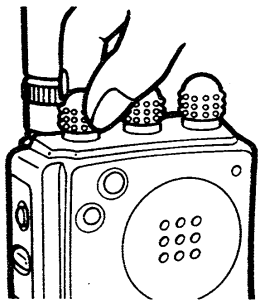

2. Select a memory channel.

Push [B MR]; then, rotate the main dial to select the desired memory channel as a priority channel.

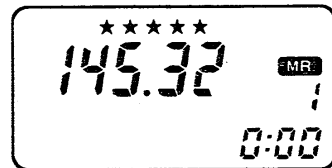
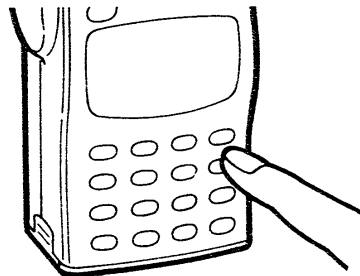

3. Start memory channel watch.

While pushing [FUNC], push [7 PRIO] to start the memory channel watch.

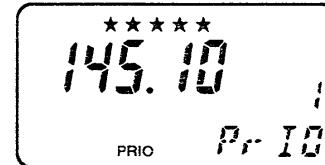
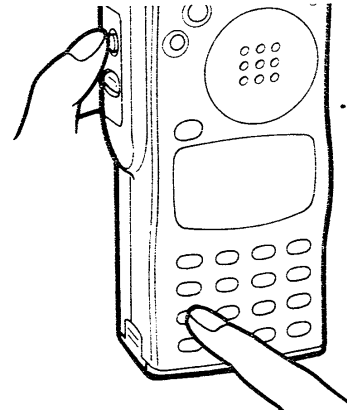

- When receiving a signal, pushing [A CLR] resumes the watch.

4. Stop the watch.

Push [A CLR].

- When receiving on the memory channel, push [A CLR] twice.

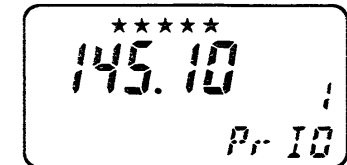
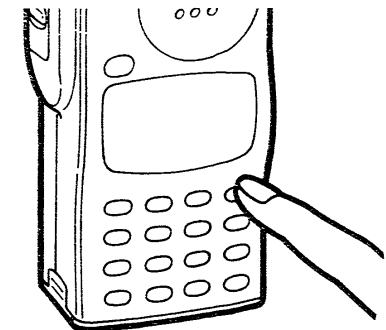

- Pushing [B MR] stops the watch and selects MEMORY mode.

13 PRIORITY WATCH

■ Memory scan watch

1. Set VFO frequency. Set squelch level.

Push [A CLR]; then, rotate the main dial to set the operating frequency.

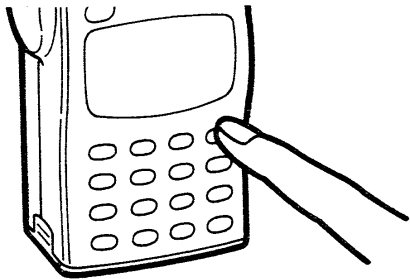

Turn [SQL] until noise disappears.

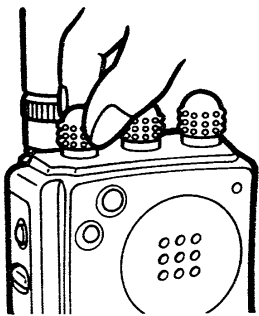

2. Start memory channel scan.

Push [B MR]; then, push and hold [* ▽] or [# △] to start the memory scan.

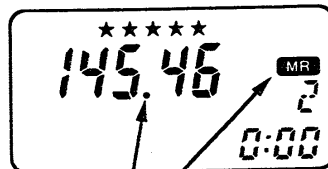
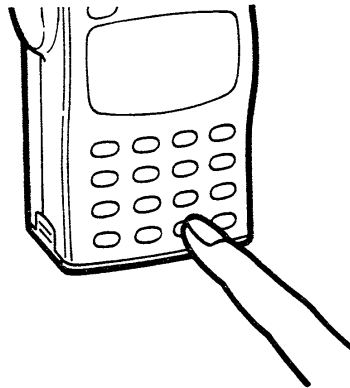

“MR” and the decimal point blink.

3. Start memory scan watch.

While pushing [FUNC], push [7 PRIO] to start the memory scan watch.

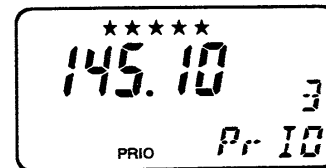
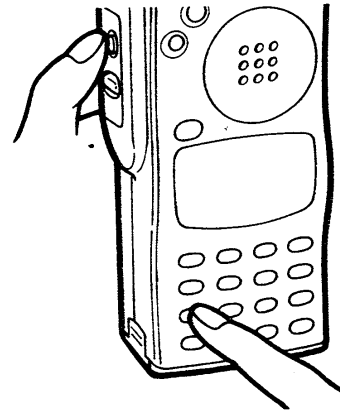

● When receiving a signal, pushing [A CLR] resumes the watch.

4. Stop the watch.

Push [A CLR].

- When receiving on a memory channel, push [A CLR] twice.

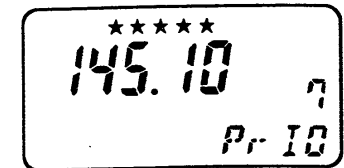
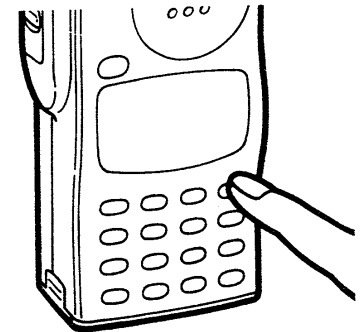

● Pushing [B MR] stops the watch and selects MEMORY mode.

■ Call channel watch

1. Set VFO frequency. Set squelch level.

Push [A CLR]; then, rotate the main dial to set the operating frequency.

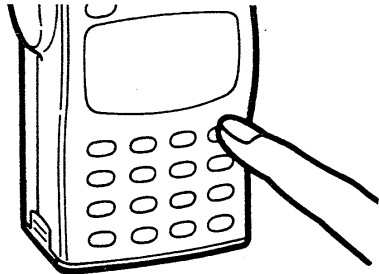

Turn [SQL] until noise disappears.

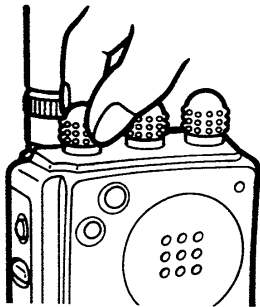

2. Select the call channel.

Push [D CALL] to select the call channel.

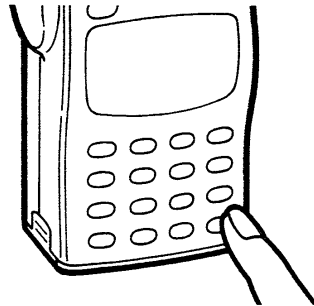

3. Start the call channel watch.

While pushing [FUNC], push [7 PRIO] to start the call channel watch.

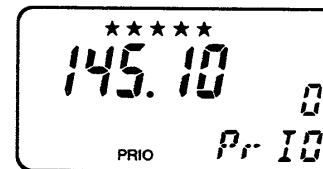
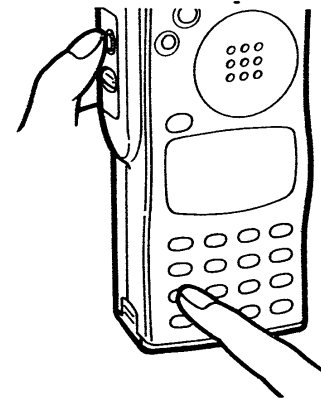

- When receiving a signal, pushing [A CLR] resumes the watch.

4. Stop the watch.

Push [A CLR].

- When receiving on the call channel, push [A CLR] twice.

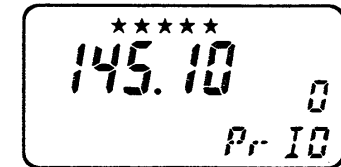
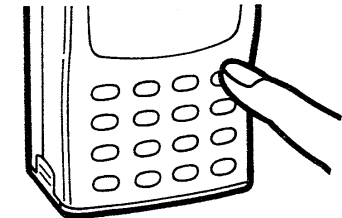

- Pushing [D CALL] stops the watch and selects the call channel.

14 DTMF MEMORY

■ General description

The transceiver has a DTMF encoder installed for transmitting DTMF signals such as telephone numbers for autopatching.

The transceiver has 16 DTMF memory channels for storage of often-used DTMF codes of up to 15 digits. Manual DTMF transmission is also possible.

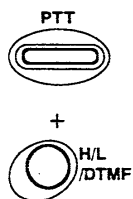

1 5 3 8 9

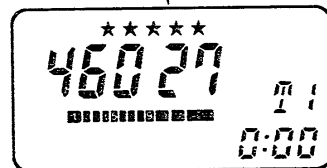

4 6 0 2 7

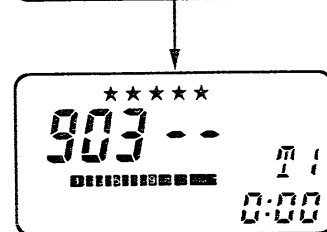

9 0 3

The programmed DTMF code is transmitted.

The function display automatically shows the transmitted DTMF digits in the sequence of their transmission.

■ Transmitting a DTMF code

Transmit a DTMF code manually.

While pushing [PTT], push the key of the desired DTMF digit.

• 1~0, A~D, * (E) and # (F) are available.

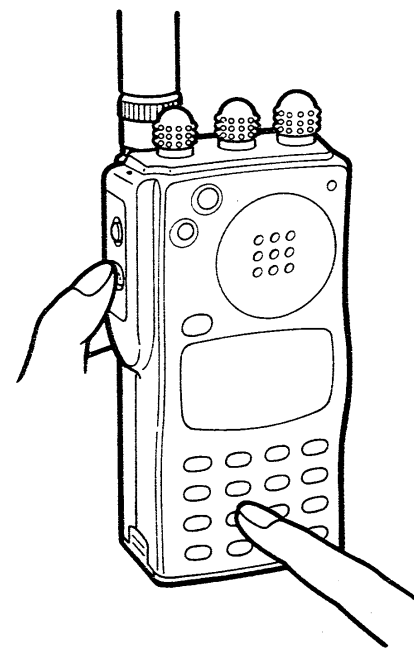

● The speaker emits the DTMF code.

■ Programming a DTMF memory

1. Select DTMF memory mode.

While pushing [FUNC], push [H/L/DTMF].

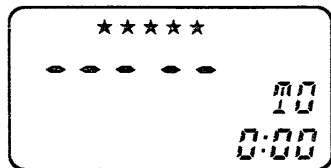
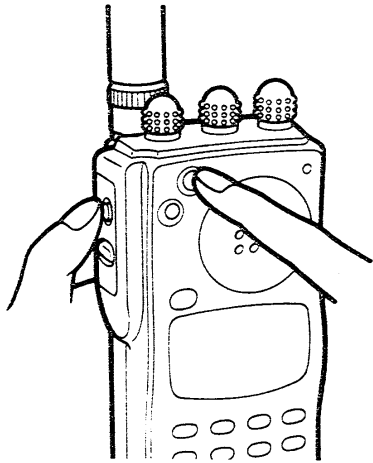

- “-----” shows no DTMF code is programmed in the displayed channel.

2. Select DTMF memory channel.

Rotate the main dial to select a desired DTMF memory channel.

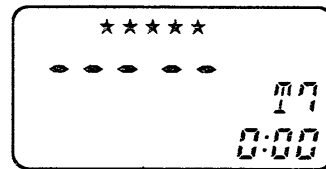
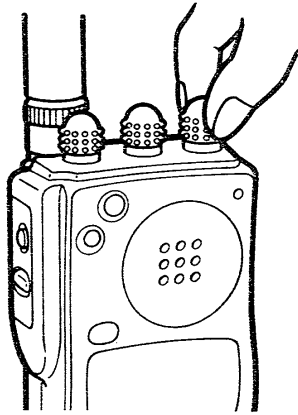

- 16 DTMF memory channels (T0~T9, TA~TF) are available.

3. Input desired DTMF code.

While pushing [FUNC], push [Ⓢ SET] to start; then, push the desired keys.

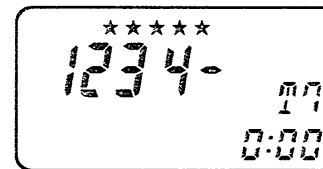
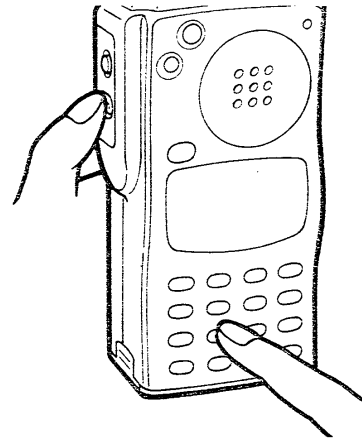

- When entering a wrong digit, push [H/L/DTMF] and repeat this step.

4. Program into memory channel.

Push [H/L/DTMF] to store the entered digits.

- If 15 digits are input in step 3, it is not necessary to push [H/L/DTMF].

Push [H/L/DTMF] again to exit DTMF memory mode.

- The programmed DTMF codes are emitted.

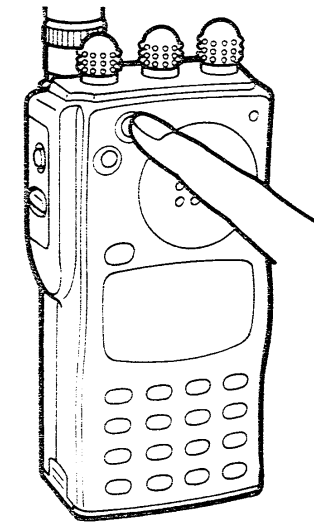

14 DTMF MEMORY

■ Transmitting a DTMF memory

1. Select DTMF memory mode.

While pushing [FUNC], push [H/L/DTMF].

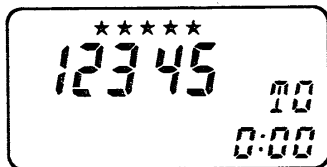
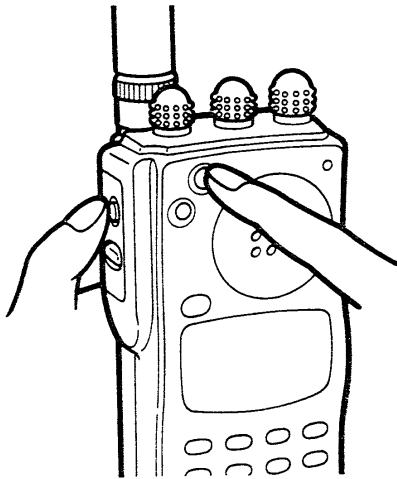

2. Select DTMF memory channel.

Rotate the main dial to select the desired DTMF memory channel.

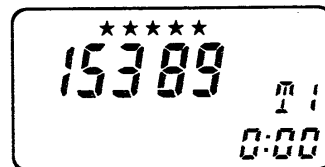
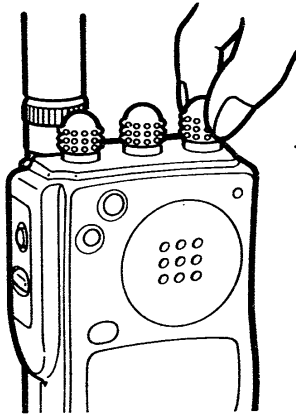

3. Exit DTMF memory mode.

Push [PTT] to exit DTMF memory mode.

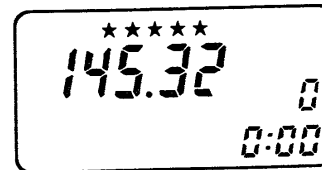
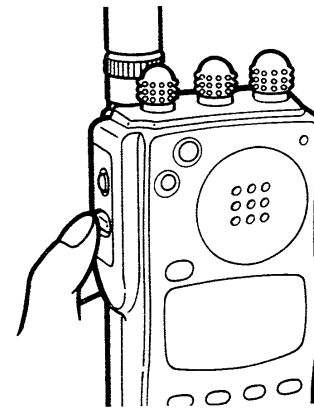

- Pushing [H/L/DTMF] also exits DTMF memory mode.

4. Transmit the DTMF code.

While pushing [PTT], push [H/L/DTMF].

- The function display shows the DTMF digits sent.

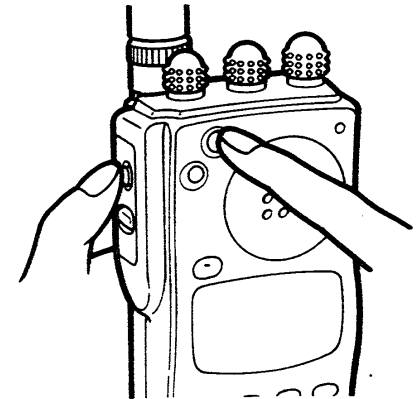



Set mode construction

★★ At least 2 stars are necessary for SET mode.
 ★★★★★ 5 stars are necessary for all displays.

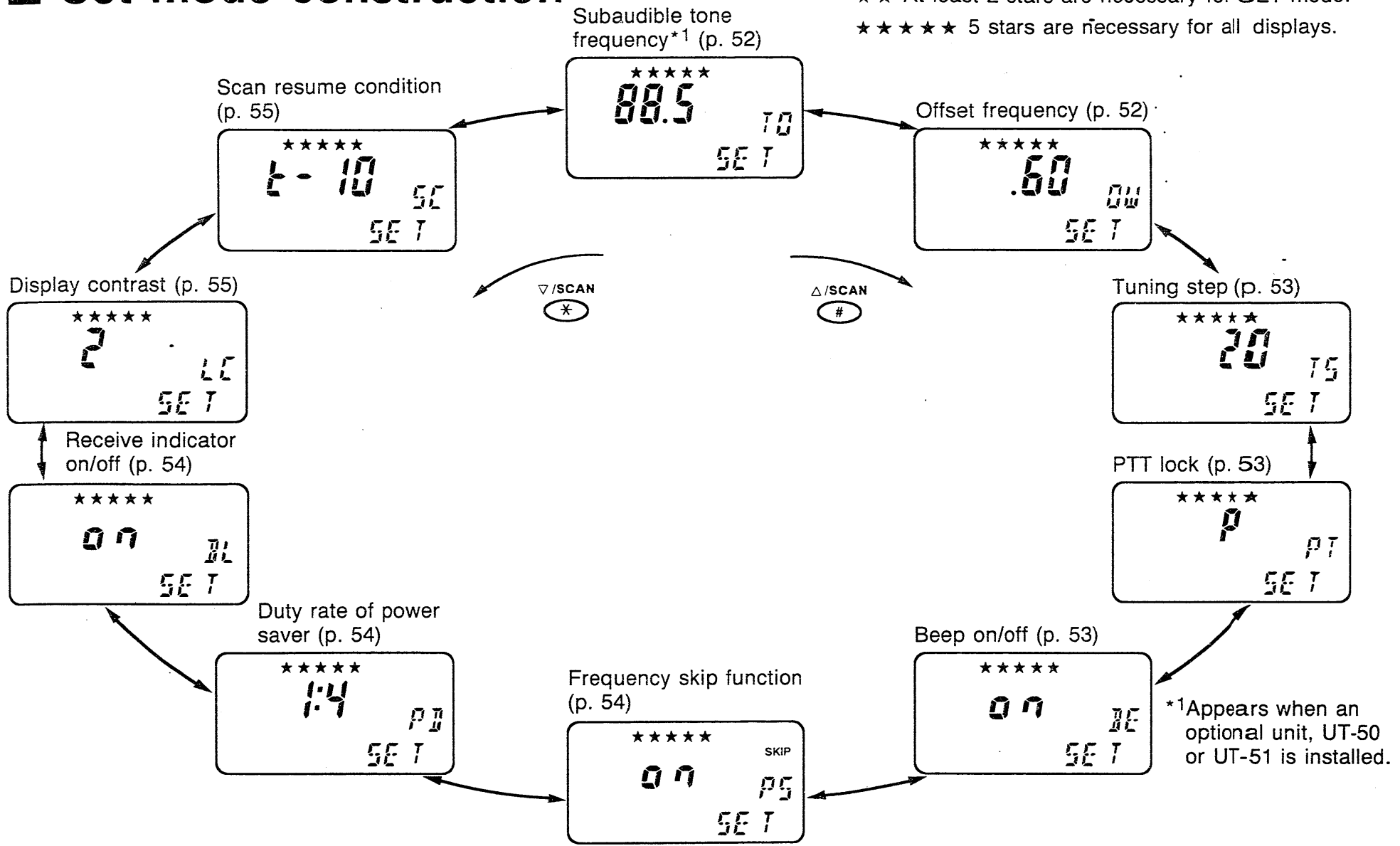

ADVANCED

15 SET MODE

■ Entering SET mode

★★ At least 2 stars are necessary to enter.
★★★★★ 5 stars are necessary for all settings.

1. Select VFO mode. Enter SET mode.

Push [A CLR] to select VFO mode.

While pushing [FUNC], push [8 SET] to enter SET mode.

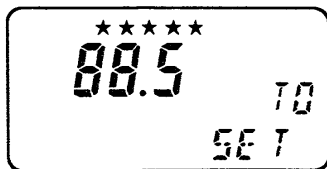
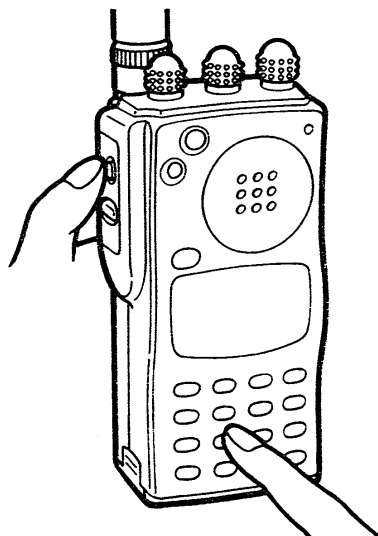

2. Select the display.

Push [* ∇] or [# Δ] several times to select the desired setting display.

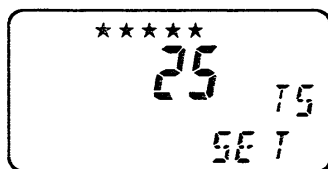
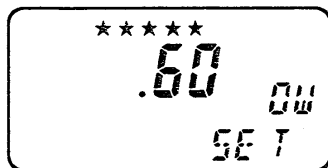
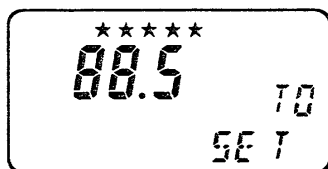
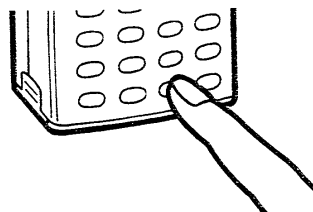

3. Select the contents.

Rotate the main dial to select the contents.

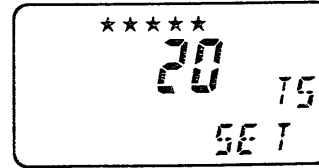
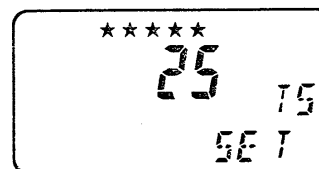
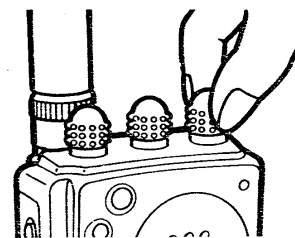

4. Exit SET mode.

Push [A CLR] or [PTT].

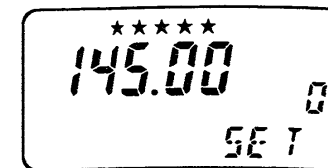
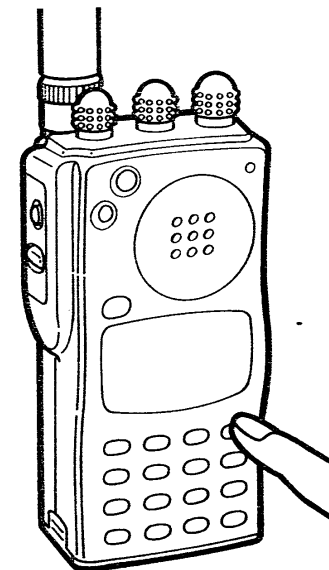

■ Setting displays

Subaudible tone frequency

When an optional UT-50 or UT-51 is installed, a subaudible tone can be transmitted.

Rotate the main dial to set the subaudible tone frequency.

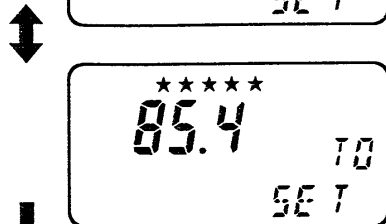
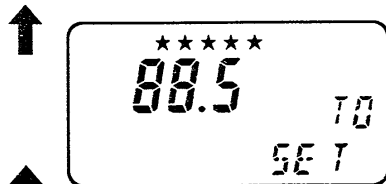
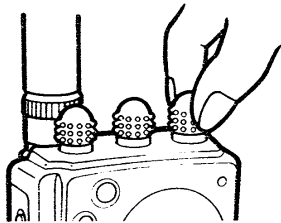

■ Subaudible tone frequency

67.0	97.4*	136.5	192.8
71.9	100.0	141.3	203.5
74.4	103.5	146.2	210.7
77.0	107.2	151.4	218.1
79.7	110.9	156.7	225.7
82.5	114.8	162.2	233.6
85.4	118.8	167.9	241.8
88.5	123.0	173.8	250.3
91.5	127.3	179.9	
94.8	131.8	186.2	(Unit:Hz)

*The UT-50 TONE SQUELCH UNIT does not have 97.4 Hz.

● This setting display does not appear without an optional UT-50 or UT-51 installed.

Offset frequency

Rotate the main dial to set the offset frequency.

● The frequency changes in the set tuning steps. (p. 53)

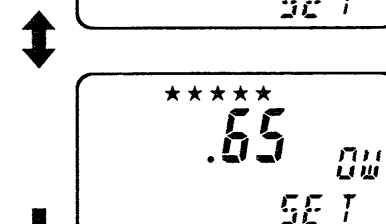
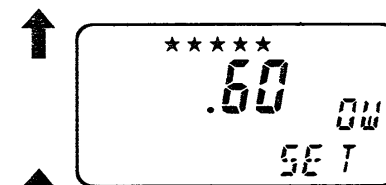
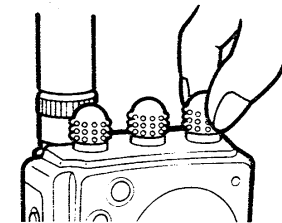

● While pushing [FUNC], rotating the main dial changes the frequency in 100 kHz steps.

15 SET MODE

Tuning step

Rotate the main dial to set the tuning step.

5, 10, 12.5, 15, 20, 25, 30 and 50 kHz are available.

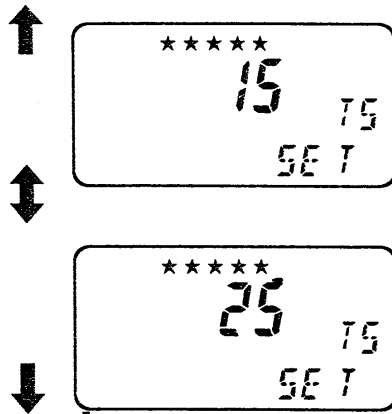
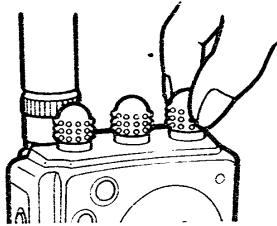

PTT lock

Rotate the main dial.

- When selecting "PL," [PTT] is electronically locked.

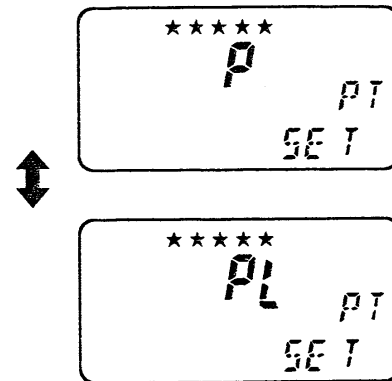
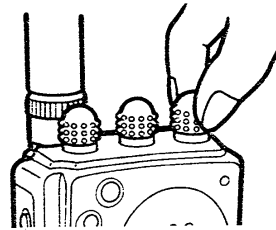

Beep on/off

Rotate the main dial.

- When selecting "on," the beep function is turned ON.

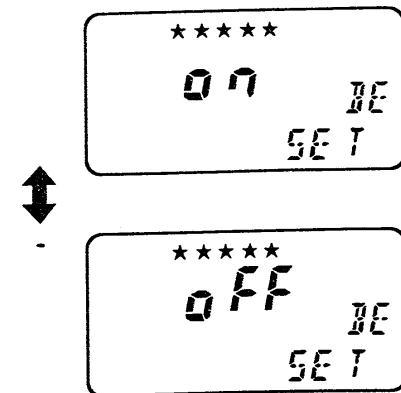
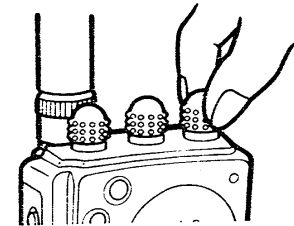

Frequency skip function

Rotate the main dial.

- When selecting "on," the frequency skip function for full scan and programmed scan is turned ON.

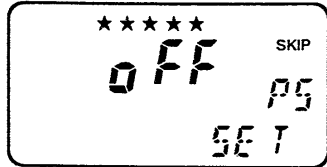
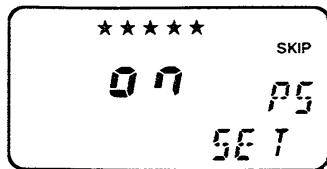
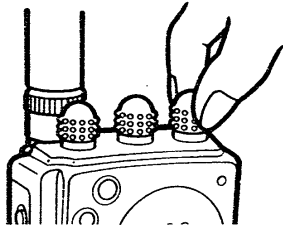

Duty rate of power saver

Rotate the main dial.

- When selecting "oFF," the power saver is turned OFF.

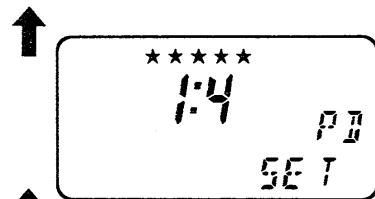
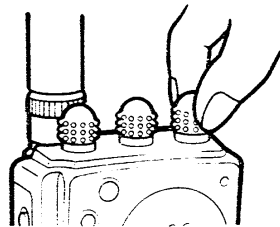

Standby:
125 msec.
Circuit off
500 msec.

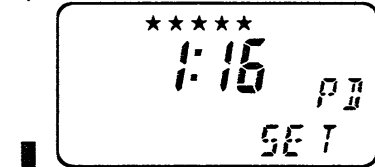

Standby:
125 msec.
Circuit off
approx. 2 sec.



Receive indicator on/off

Rotate the main dial.

- When selecting "on," the receive indicator (busy LED) is turned ON.

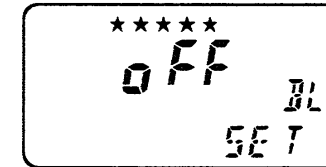
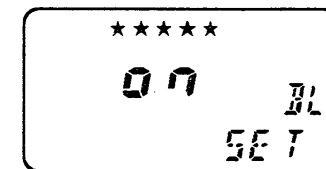
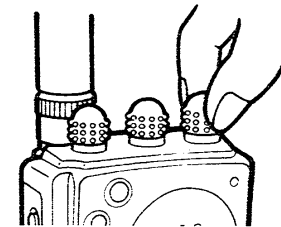

15 SET MODE

Display contrast

Rotate the main dial.

- The contrast level can be changed in 4 steps:
1 (lightest) ~ 4 (heaviest).

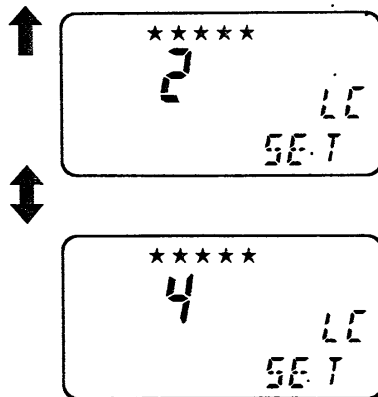
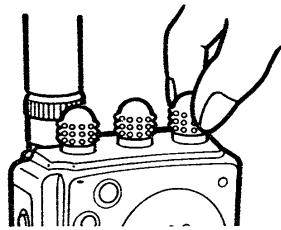

Scan resume condition

Rotate the main dial to set the desired timer.

- t-10 : Scan pauses 10 sec. while receiving signal.
- t-05 : Scan pauses 5 sec. while receiving signal.
- P-02 : Scan pauses until a signal disappears and then resumes 2 sec. after that.

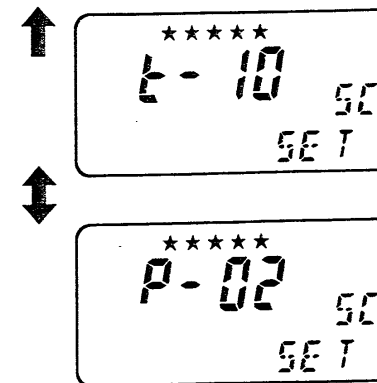
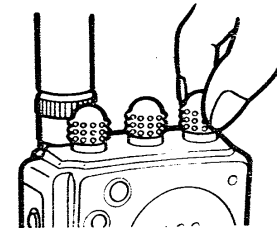

- The pause time of the priority watch is fixed and has no relation with resume condition.

■ What does AI in the transceiver do?

The AI in this transceiver has 2 important functions, "Learning Function" and "Automatic Order Selection."

• Learning function

The AI automatically assigns one of the transceiver functions, shown in the table at right, to the [AI] key after it is used. This function is then displayed in the function display and can be conveniently reaccessed by simply pushing the [AI] key. Because the transceiver 'learns' the last used function, this is called the "Learning Function."

In some cases, this automatic assignment of functions to the [AI] key may be inconvenient and for this reason the learning function can be turned OFF. The transceiver functions can then be manually assigned to the [AI] key.

• Automatic order selection

The AI changes the order in which functions can be selected via the [AI] key. To illustrate this, push and hold the [AI] key; then, rotate the main dial. As an example, you find the following order: [MASK], [SCAN], [PRIO], [DUP], etc. and you push the [AI] key when [PRIO] appears. The order changes to [PRIO], [MASK], [SCAN] and [DUP]. In order words, the AI keeps track of which function you use and when. It then orders them accordingly. This order is convenient when the learning function is OFF and you are manually assigning transceiver functions to the [AI] key.

DISPLAY	FUNCTION
<i>TONE*</i>	Tone encoder/Tone squelch/Pocket beep
<i>PGM*</i>	Pager/Code squelch
<i>SKIP</i>	Skip setting
<i>DUP</i>	Duplex setting
<i>CODE*</i>	Code setting
<i>MASK</i>	Memory mask
<i>PRIO</i>	Priority watch
<i>SET</i>	SET mode
<i>TIME</i>	Timer setting
<i>SCAN</i>	Scan
<i>0:00</i>	Time indication

*These indications appear when an optional unit is installed.

■ Learning function

When the learning function is on:

To use the [AI] key as [FUNC] + [6 MASK].

Select a memory channel to mask.

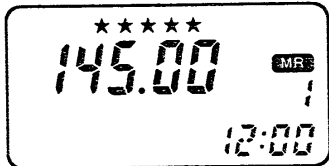

While pushing [FUNC], push [6 MASK].

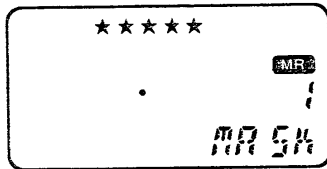

Confirm that "MR 5K" is indicated in the AI function indicator.

- This means that [MASK] is now assigned to the [AI] key.

Push [AI] again to recall the masked channel.



Select another memory channel to mask.

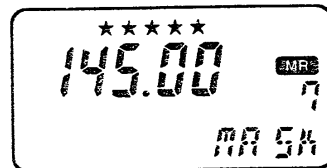

Push [AI] to mask the channel.

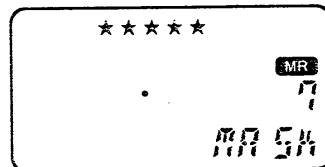

■ Learning function on/off

To turn the function on/off:

While pushing [A CLR] and [AI], turn the power ON to deactivate the learning function.

- All indications appear for 2 sec.

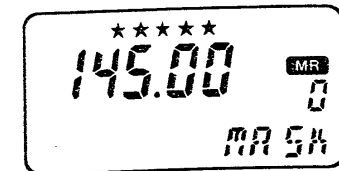
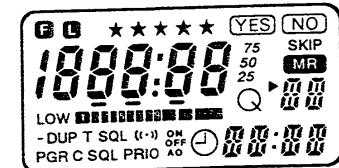
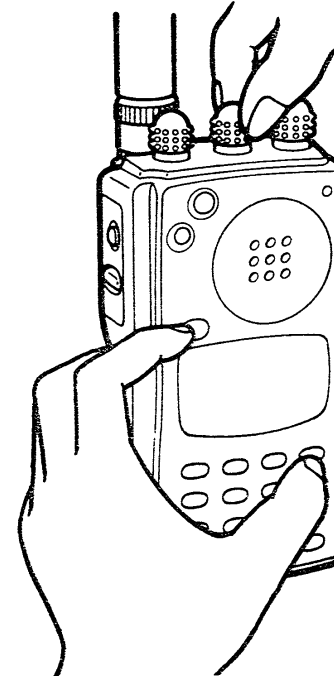

- To change the function of [AI], see the page at right.
- To turn the learning function ON, perform the above operation again (while pushing [A CLR] and [AI], turn the power ON).

■ Setting a function to the [AI] key manually

1. Select AI selection mode.

Push and hold [AI] until "AI" flashes in the display.

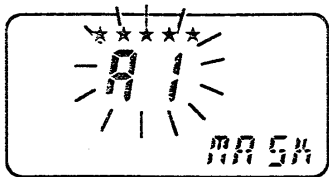
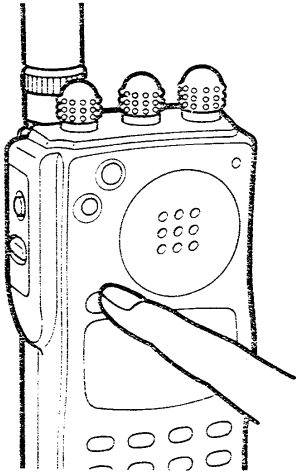

2. Select the function.

Rotate the main dial to select the desired function.

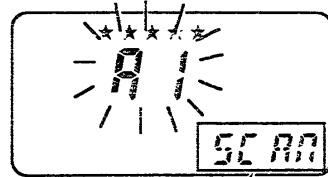
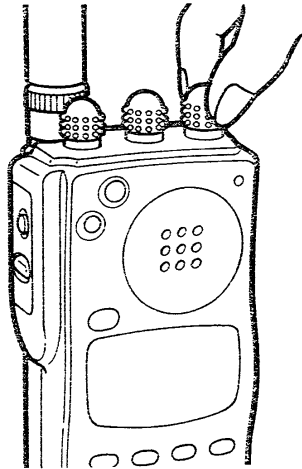

The function order can be observed here.

3. Exit AI selection mode.

Push [AI].

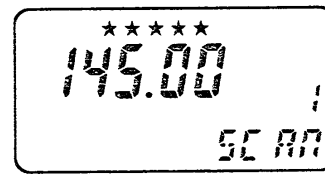
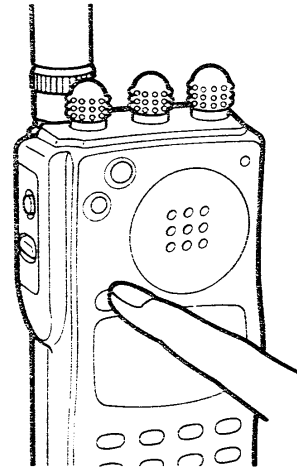

- Push [PTT] to cancel the selection and exit AI selection mode.

4. Activate the function.

Push [AI].

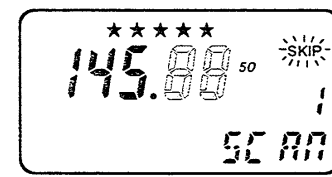
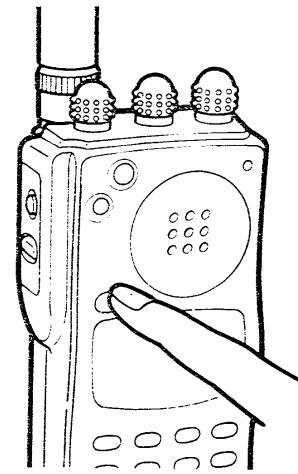

17 CLOCK AND TIMER

TIMER mode

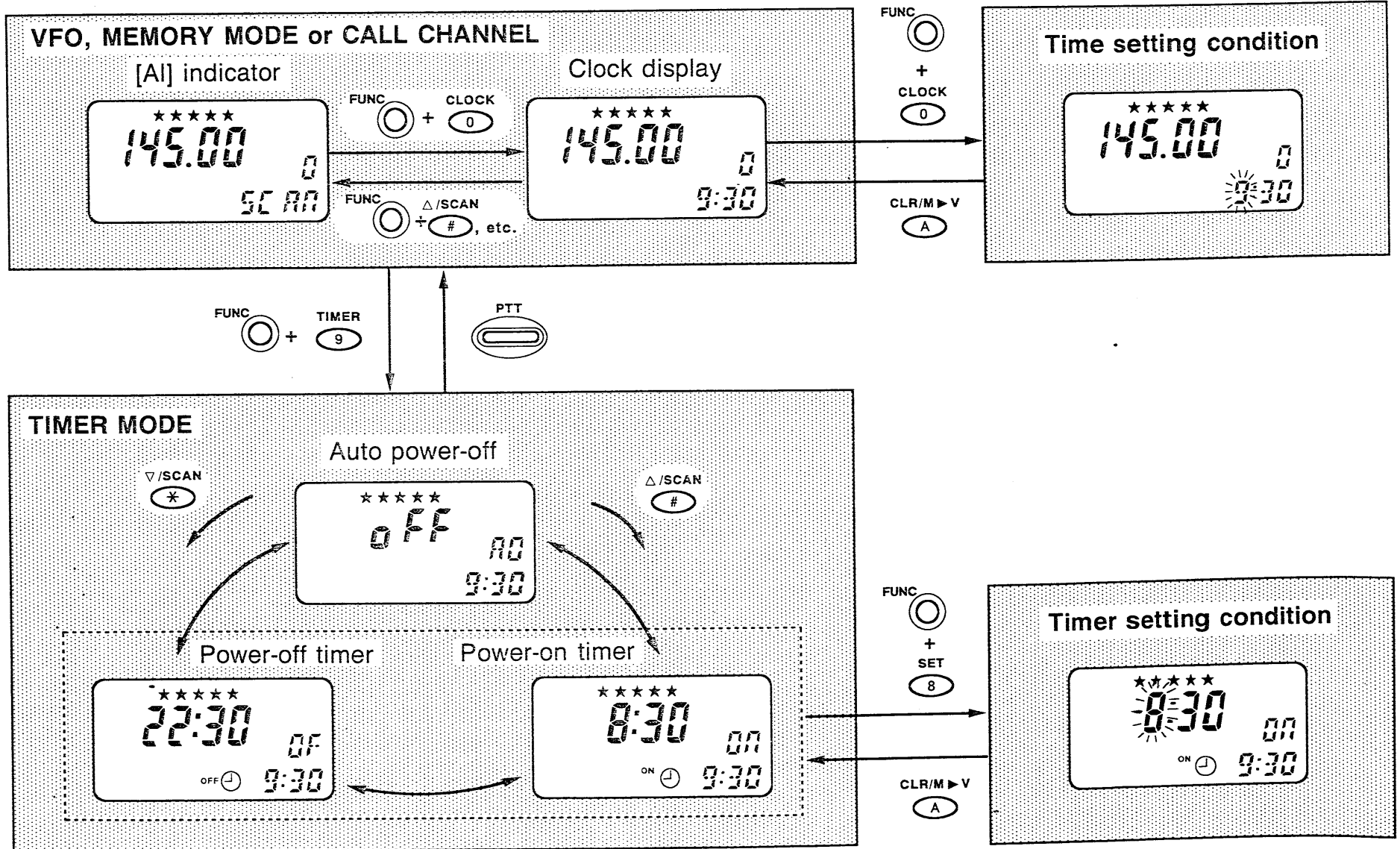

■ Setting the time

1. Select the clock display.

While pushing [FUNC], push [CLOCK] to call up the clock display.

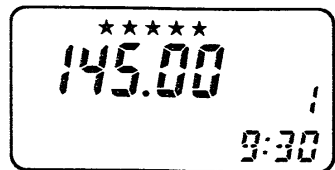
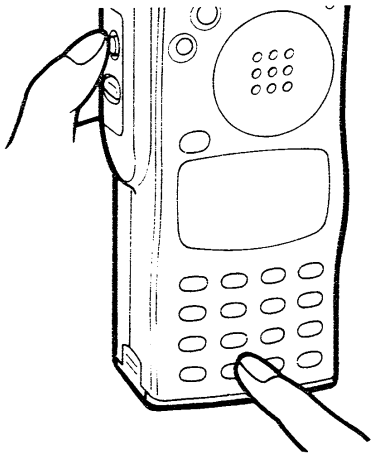

- **TIME ERROR:**
± 1 min./week

2. Enter the time setting condition.

While pushing [FUNC], push [CLOCK] to enter the time setting condition.

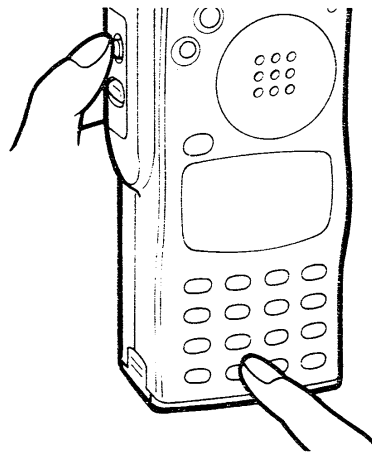

3. Set the time.

Rotate the main dial to set the hour. (24-hour system)



Push [* ▽] or [# △]; then, rotate the main dial to set the minutes.



4. Start the clock.

Push [A CLR].

- The colon starts blinking.

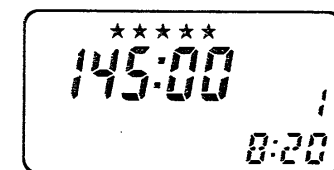
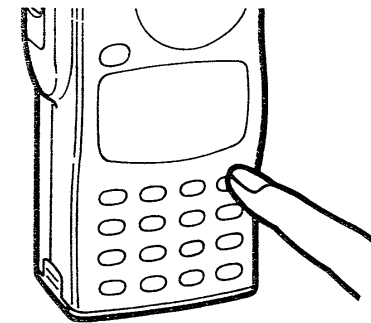

- Push [PTT] to exit the time setting condition.

17 CLOCK AND TIMER

■ Power-on timer — Setting the power-on timer to 7:30.

★★★★★ 5 stars are necessary.

1. Set the operating condition.

Push [A CLR]; then, rotate the main dial to set the operating frequency.

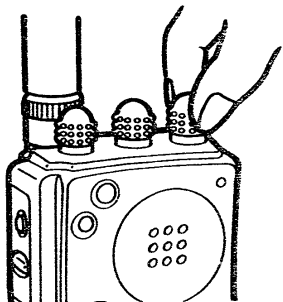

Turn [PWR/VOL] to the desired audio level.

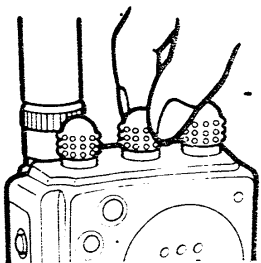

2. Select TIMER mode.

While pushing [FUNC], push [9 TIMER] to select TIMER mode.

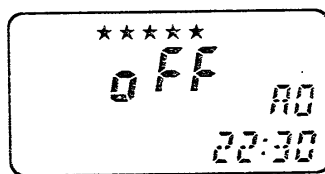
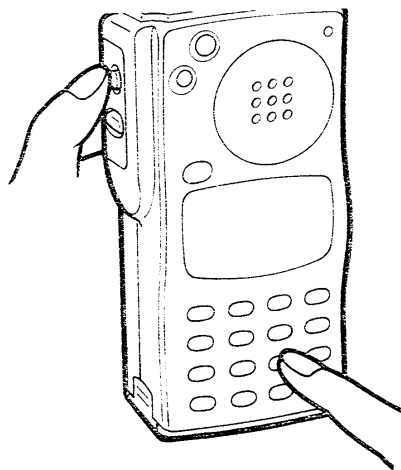

3. Select power-on display.

Push [* ∇] or [# Δ] to select the power-on display.

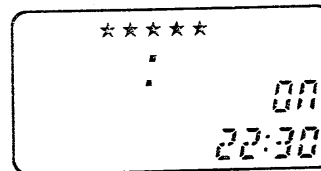
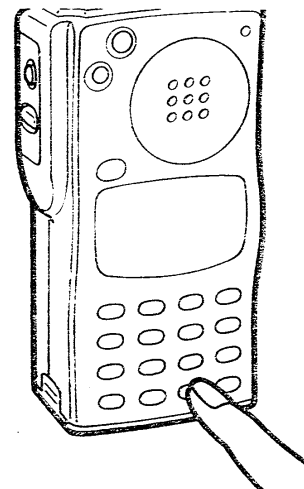

4. Recall power-on time.

While pushing [FUNC], push [9 TIMER] to recall the previous power-on time.

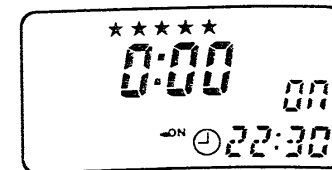
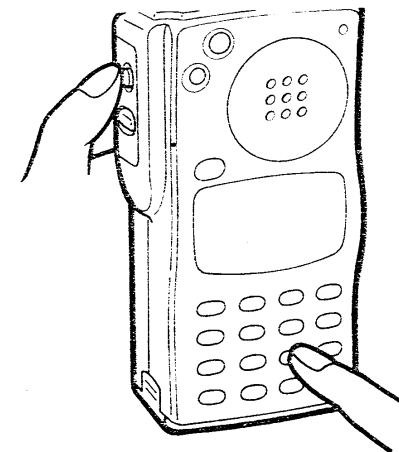

5. Set power-on time.

While pushing [FUNC], push [Ⓢ SET]; then, rotate the main dial to set the hour.



Push [⊛ ▽] or [⊕ △]; then, rotate the main dial to set the minutes.

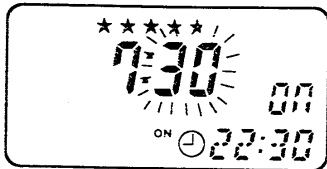

Push [Ⓐ CLR] to enter the time.

6. Activate power-on timer.

While pushing [FUNC], push [Ⓐ CLR].

- The function display shows the time and the transceiver is in the OFF condition.
- When the set time arrives, the power is automatically turned ON with 5 beeps.

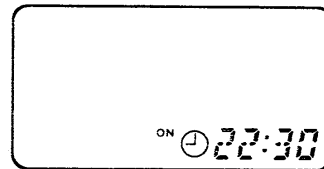
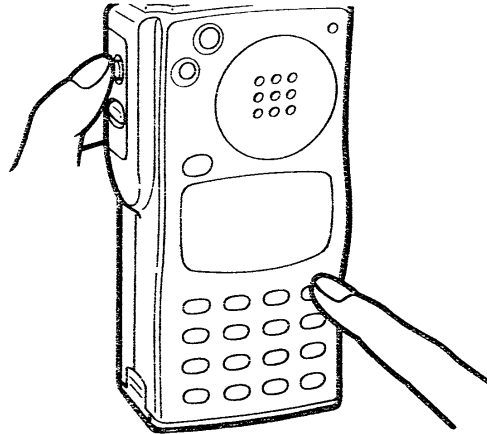

Cancel power-on timer.

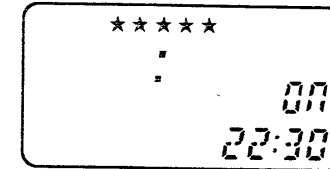

Repeat steps 2 ~ 4 to mask the set time. Push [PTT] to exit TIMER mode.

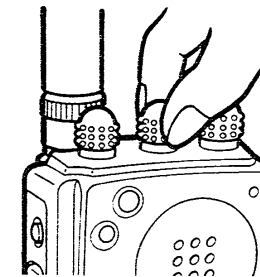

- To turn power ON while in the OFF condition, turn power OFF then ON again using [PWR/VOL].

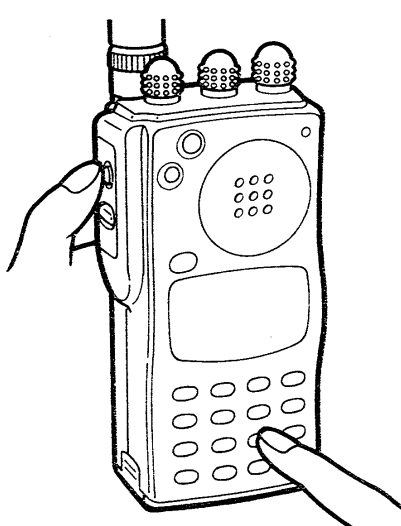
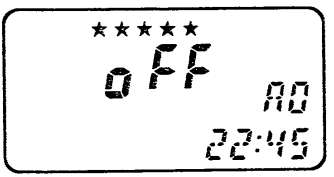
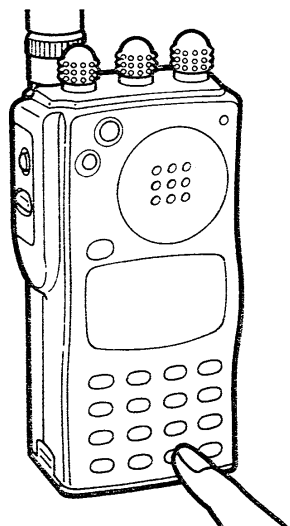
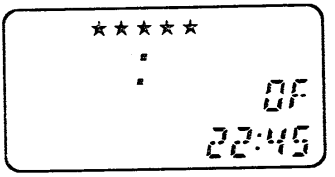
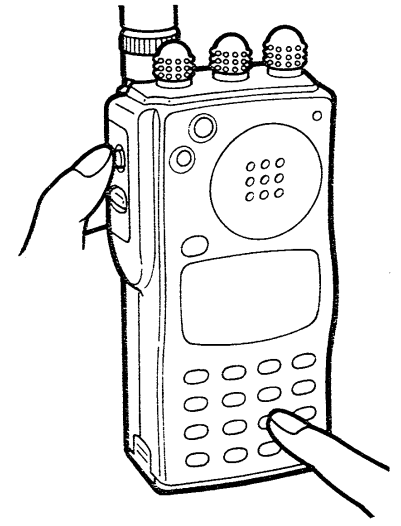
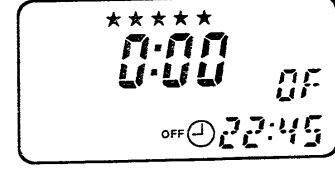
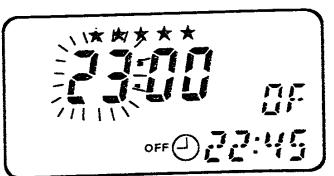

■ Power-off timer — Setting the power-off timer to 23:30. ★★★★★ 5 stars are necessary.

<p>1. Select TIMER mode.</p> <p>While pushing [FUNC], push [9 TIMER] to select TIMER mode.</p>  	<p>2. Select power-off display.</p> <p>Push [* ▽] or [# △] to select power-off display.</p>  	<p>3. Recall power-off time.</p> <p>While pushing [FUNC], push [9 TIMER] to recall the previous power-off time.</p>  	<p>4. Set power-off time.</p> <p>While pushing [FUNC], push [8 SET]; then, rotate the main dial to set the hour.</p>  <p>Push [* ▽] or [# △]; then, rotate the main dial to set the minutes.</p>  <p>Push [A CLR] to enter the time.</p>
--	---	---	---

5. Activate power-off timer.

Push [PTT] to exit TIMER mode.

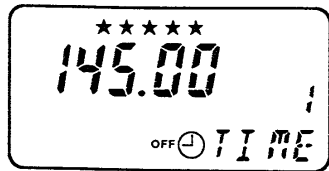
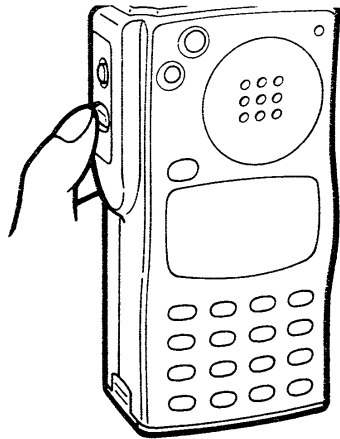

- Turn OFF the auto power-off function when using the power-off timer. (p. 65)

6. When the set time arrives.

When the set time arrives, the power is automatically turned OFF with 5 beeps.

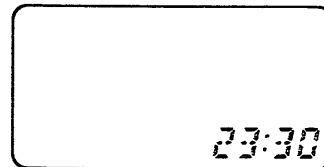

- To turn power ON while in the OFF condition, turn power OFF then ON again using [PWR/VOL].

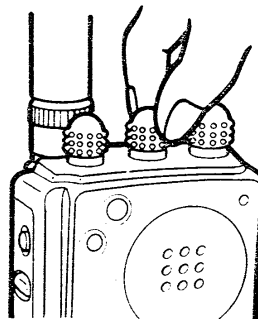

Cancel power-off timer.

Repeat steps 1 ~ 3 to mask the set time.

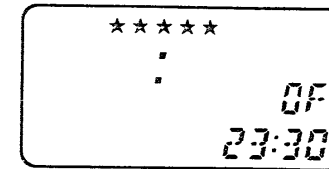

Push [PTT] to exit TIMER mode.

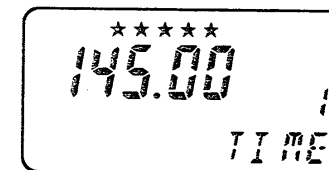

17 CLOCK AND TIMER

■ Auto power-off

The transceiver automatically turns OFF after a selected period in which no switch is pushed or no signal is received.

60 min., 40 min., 20 min. and OFF can be selected.

The selected period is retained even when the transceiver is turned OFF by the auto power-off function. To cancel the function, select "oFF" in step 3 at right.

★★★★★ 5 stars are necessary.

1. Select timer mode.

While pushing [FUNC], push [9 TIMER] to select TIMER mode.

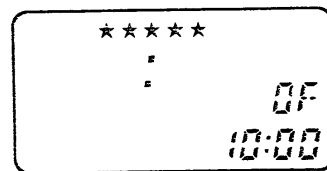
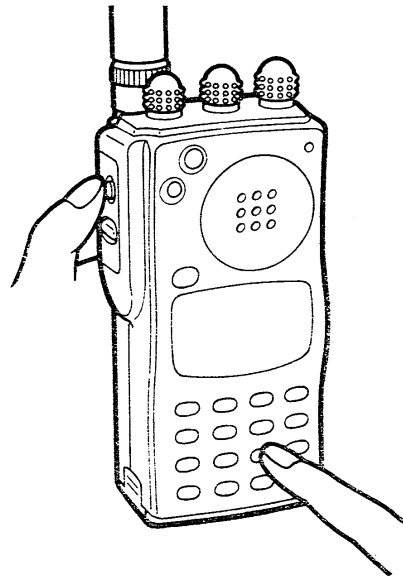

2. Select auto power-off display.

Push [* ▽] or [# △] to select the auto power-off display.

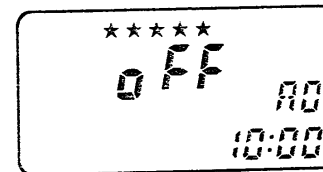
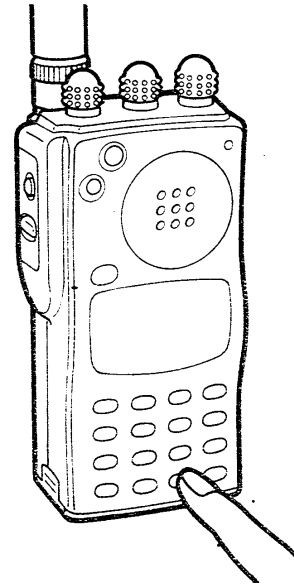

3. Set auto power-off time.

Rotate the main dial to select auto power-off time.

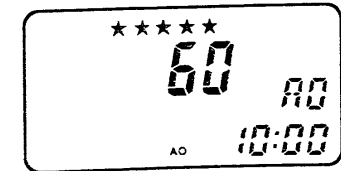

Push [PTT] to exit TIMER mode.

- When the set period passes, the power is automatically turned OFF with 5 beeps.



■ Unit installation

UT-49 DTMF DECODER UNIT

Provides pager and code squelch functions.

UT-50 TONE SQUELCH UNIT

Provides pocket beep and tone squelch functions. Also functions as a programmable tone encoder.

UT-51 PROGRAMMABLE TONE ENCODER UNIT

Allows you to access a repeater requiring a subaudible tone.

1. Turn power OFF.

Turn power OFF, then remove the battery pack or case.

Unscrew the 6 screws as shown in the diagram below.

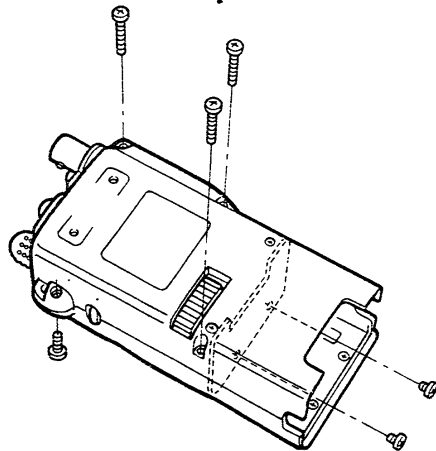

2. Disassemble the transceiver.

Carefully open the transceiver.

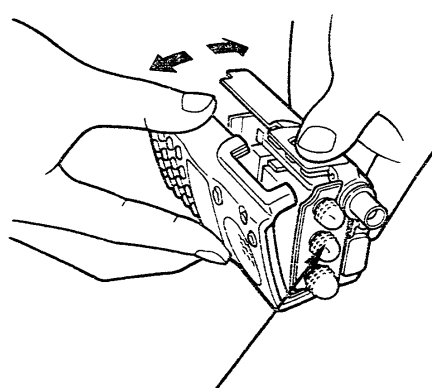

Keep the rear panel attached.

CAUTION:

Flexible cables are fragile and can be damaged by mishandling.

3. Install an optional unit.

Install the optional unit as shown in the diagram below.

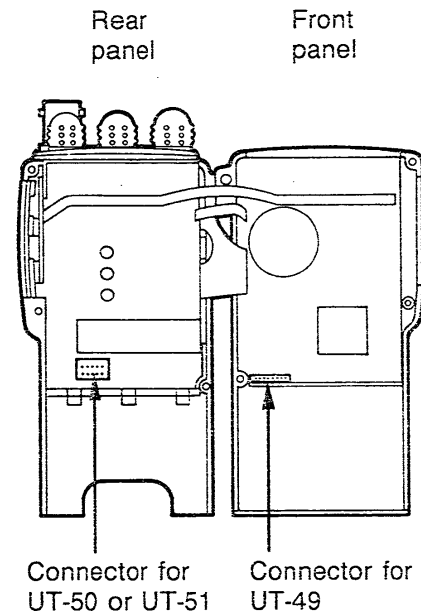

- After installing the unit, reassemble the transceiver.

19 PAGER AND CODE SQUELCH

■ General description

• Pager

The pager function is a selective calling system using DTMF codes. With the pager, you can call any one or all the stations in your group, and you can receive a specified call from a station in your group. To use the pager function in your group, all stations need the pager function.

The transmit station sends a code consisting of a transmit code and the transmit station's ID code. If the transmit code matches the code programmed in the code channel of the receive station, the transceiver in the receive station informs the operator with beeps. For a personal call, the ID code of the receive station is used as the transmit code. For a group call, the group code is used as the transmit code.

The pager code for a call =

Transmit code + "*" + Transmit station's ID code.

The receive station can recognize the transmit station by the received ID code of the transmit station and can easily answer back because the received ID code is automatically programmed as a transmit code for answer back.

The pager code for answer back =

Received ID code + "*" + Receive station's ID code.

During pager or code squelch operation, the power saver duty rate becomes 1:1 if the power saver is activated.

An optional UT-49 is necessary for operation.

[PAGER SIMULATION]: Personal call

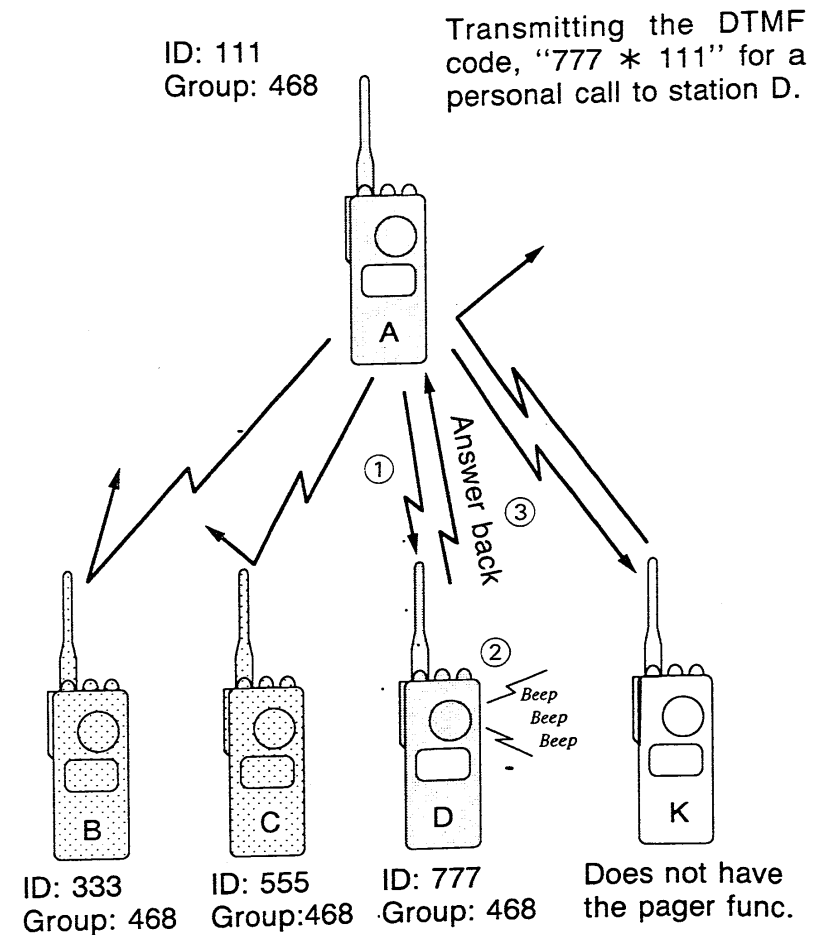

[PAGER SIMULATION]: Group call

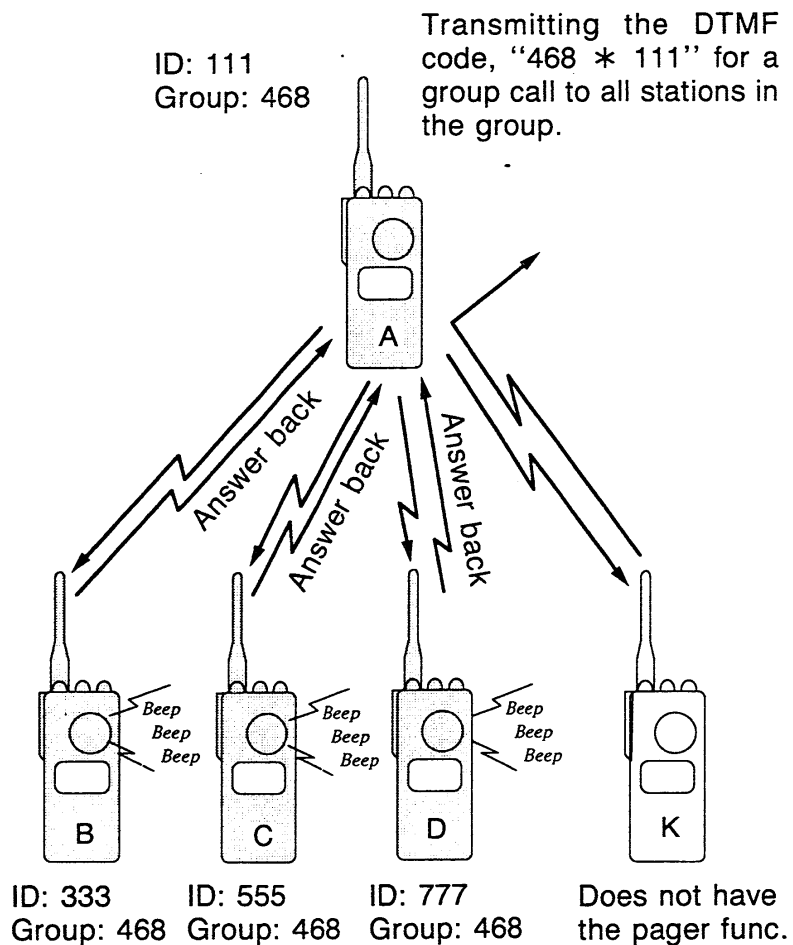

• **Code squelch**

Code squelch allows communication with quiet standby since you will only receive calls from stations which know your ID code.

Prior to voice transmission, the ID code of the transmitting station is transmitted in order to open the receiving station's code squelch.

[CODE SQUELCH SIMULATION]

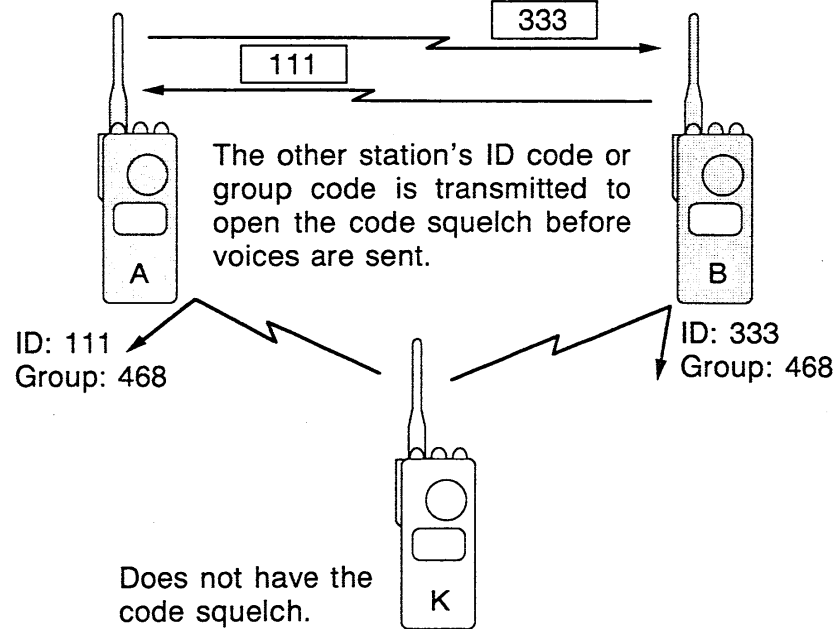

19 PAGER AND CODE SQUELCH

■ Code channel

• Before programming

The pager and code squelch functions require ID codes and a group code. These codes are 3-digit DTMF codes and must be written into the code channels before operation.

• Code channel assignment

ID or group code	Code channel number	"Receive accept" or "Receive inhibit"
Your ID code	C0	"Receive accept" only.
Other station's ID code	C1 ~ C5	"Receive inhibit" should be programmed in each channel.
Group code	One of C1 ~ C5	"Receive accept" must be programmed.
Memory space*	CP	"Receive inhibit" only.

*Channel CP automatically memorizes an ID code when receiving a pager call. The contents in channel CP cannot be changed.

"RECEIVE ACCEPT" OR "RECEIVE INHIBIT"

Code channels C1 ~ C5 should be effectively programmed as "Receive accept" or "Receive inhibit."

- "Receive accept" ("SKIP" indicator is not illuminated) accepts pager calls when the transceiver receives a signal with a code the same as that in the code channel.
- "Receive inhibit" ("SKIP" indicator is illuminated) rejects calls when the transceiver receives a signal with a code the same as that in the code channel.

For example, the code channel that stores the group code should be programmed as "Receive accept." If the channel is programmed as "Receive inhibit," you cannot receive group calls.

The code channels that store other station's ID code for a transmit code should be programmed as "Receive inhibit." If the channels are programmed as "Receive accept," personal calls for stations other than you will be received.

■ Programming a code channel

1. Call up a code channel.

While pushing [FUNC], push [5] CODE, then rotate the main dial to select the desired code channel.

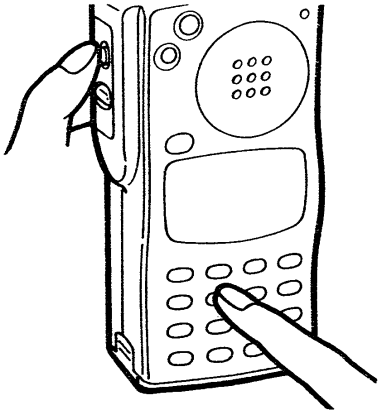

- Code channel CP cannot be used for programming.

2. Program a code channel.

Push numeral keys to enter the desired digit code.

- Digits are automatically stored once the 3rd digit has been entered.

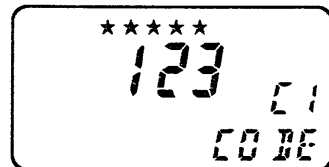
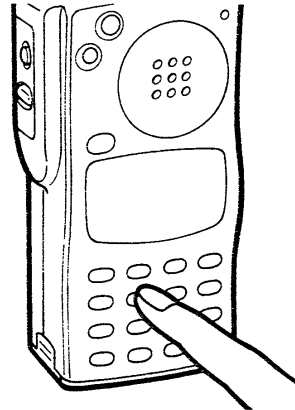

- When a wrong digit is entered, push [A] CLR and repeat this step.

3. Set "inhibit" or "accept."

While pushing [FUNC], push [3] SKIP to set the code channel for "Receive inhibit" or "Receive accept."

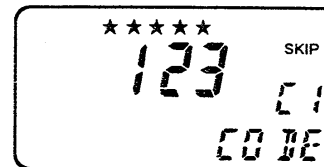
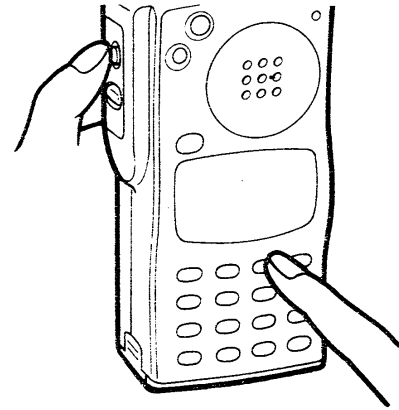

- When "Receive inhibit" is set, "SKIP" is illuminated.

4. Exit the code channel.

Push [PTT].

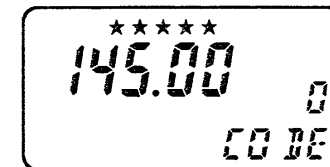
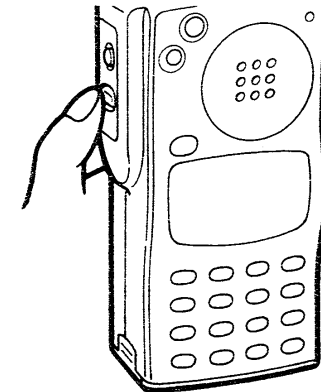

■ Pager operation

1. Set the operating frequency.

Push [A CLR]; then, rotate the main dial to set the operating frequency.

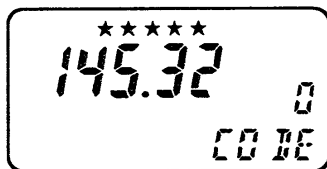
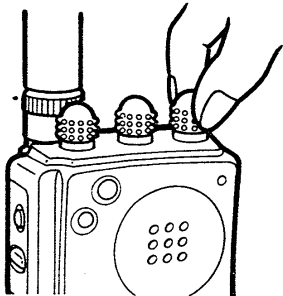

- An optional tone squelch can be used with the pager function. (p. 79)

2. Select the code channel.

While pushing [FUNC], push [5 CODE]; then rotate the main dial.

- Select a code channel which includes the ID code of the receive station or the group code to be used as a transmit code.



Push [PTT] to exit the setting display.

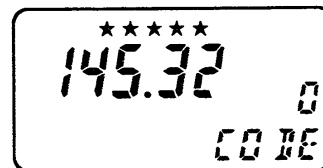

3. Activate the pager function.

While pushing [FUNC], push [2 PGR] to turn the pager function ON.

- "PGR" appears.

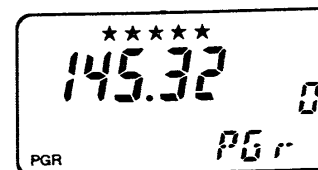
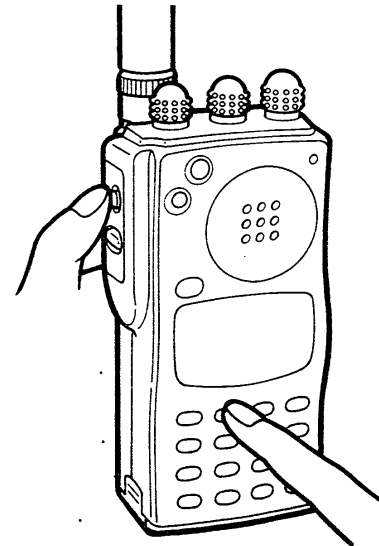

4. Transmit the pager code.

Push [PTT].

- The speaker emits the pager code.

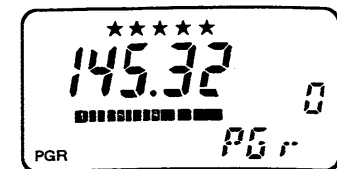
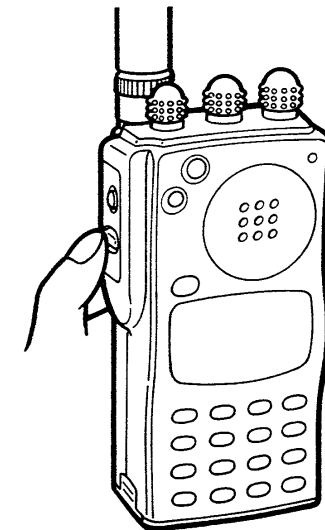

5. Wait for an answer back.

Wait for an answer back.

- When the transceiver receives an answer back code, the function display shows as follows with a beep.

When called with your group code:

Group code appears.



When called with your ID code:

Other station's ID code appears.

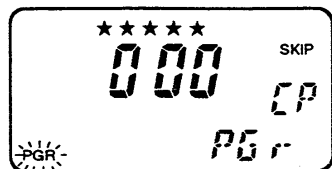

6. Exit the code display.

After confirming a connection, push [PTT] to display the operating frequency.

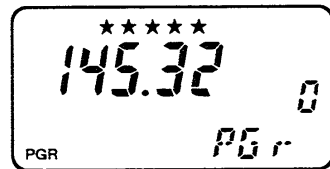
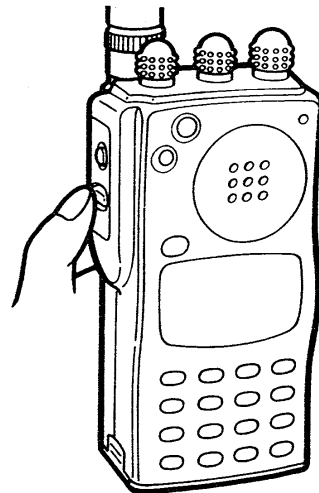

7. Exit the pager function.

While pushing [FUNC], push [2] PGR/C-SQL once to select the code squelch or twice to select the non-selective calling system.

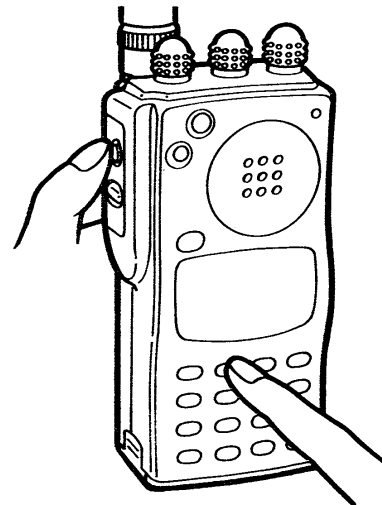

Error information

When the transceiver receives an incomplete signal, the function display shows "E" and the last-used code or group code.

Group code



Last-used code

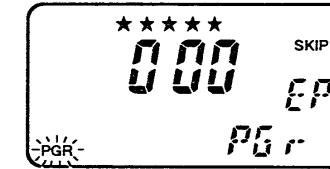

■ Waiting for a call from a specific station

1. Set the operating frequency.

Push [A CLR]; then, rotate the main dial to set the operating frequency.

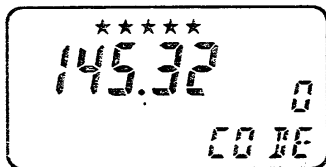
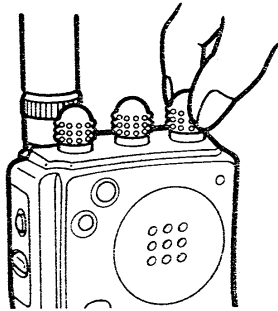

- An optional tone squelch can be used with the pager function. (p. 79)

2. Activate the pager function.

While pushing [FUNC], push [PGR] to turn the pager function ON.

- "PGR" appears.

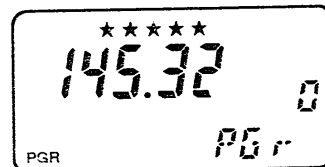
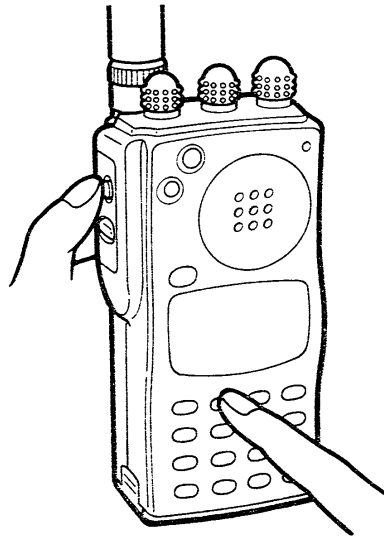

3. Wait for a call.

Wait for a call.

- When the transceiver receives the correct code, the function display shows the code as follows with a beep.

When called with your group code:
Group code appears.



When called with your ID code:
Other station's ID code appears.



4. Transmit an answer back call.

Push [PTT] to transmit an answer back call and display the operating frequency.

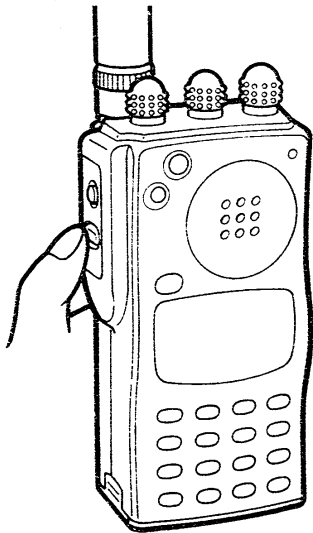

5. Exit the pager function.

While pushing [FUNC], push [PGR/C-SQL] once, to select the code squelch, or twice, to select the non-selective calling system.

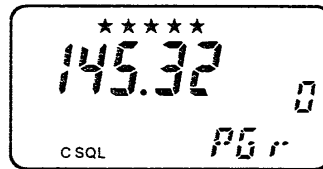
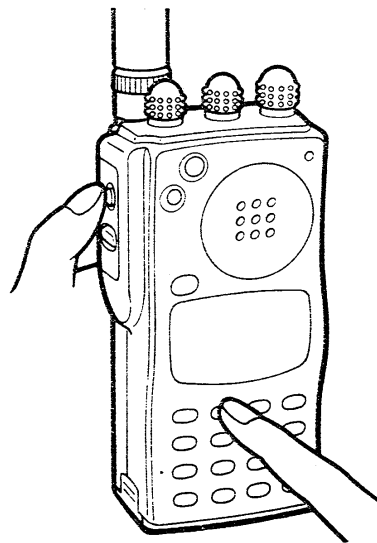

Error information

When the transceiver receives an incomplete signal, the function display shows "E" and the last-used code or group code.

Group code

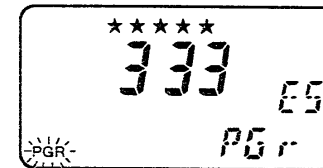

Last-used code

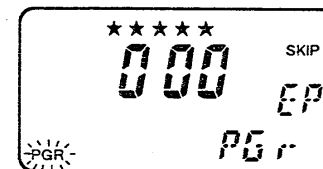

OPTIONS

■ Code squelch operation

1. Set the operating frequency.

Push [A CLR]; then, rotate the main dial to set the operating frequency.

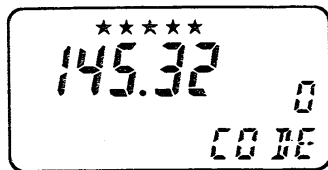
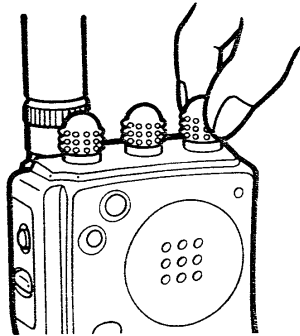

- An optional tone squelch can be used with the code squelch function. (p. 79)

2. Select a code channel.

While pushing [FUNC], push [5 CODE], then rotate the main dial to select a code channel which includes the ID code of the receive station or the group code to be used as a transmit code.

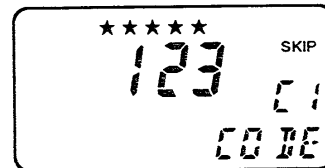

Push [PTT] to exit the setting display.

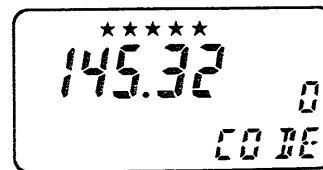

- After calling with the pager, the transmit code is automatically set. Skip to step 3 at right.

3. Activate code squelch function.

While pushing [FUNC], push [2 PGR/C-SQL] once from pager operation or twice from the non-selective calling operation.

- "C SQL" appears.

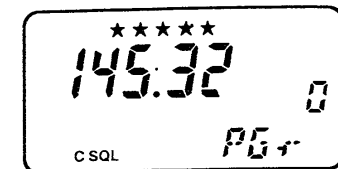
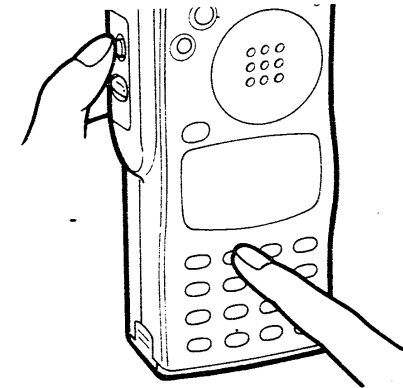

4. Operate the transceiver.

Operate the transceiver in the normal way (push [PTT] to transmit; release [PTT] to receive).

- A 3-digit transmit code is sent each time [PTT] is pushed.

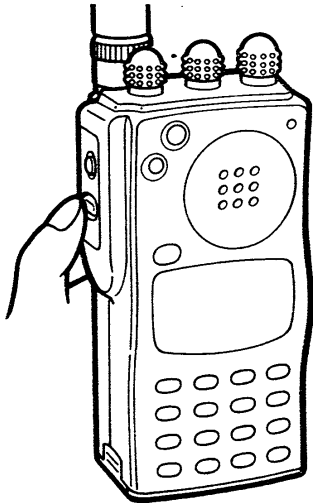

5. Cancel the code squelch function

While pushing [FUNC], push [② PGR/C-SQL] to cancel the code squelch and select the non-selective calling system.

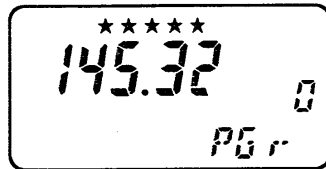
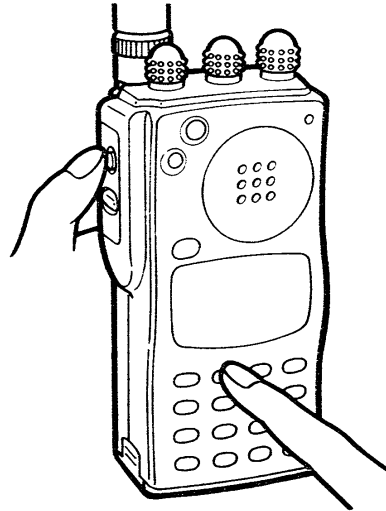

20 POCKET BEEP AND TONE SQUELCH

■ Pocket beep operation

An optional UT-50 is necessary for operation.

The pocket beep function is a selective calling system using a subaudible tone. If your transceiver receives a subaudible tone that matches the tone programmed into your transceiver, beeps are emitted for up to 30 sec. to alert you.

To call a station with the pocket beep function, transmit a subaudible tone that matches the tone of the receiving station. (The receiving station must also have the pocket beep function).

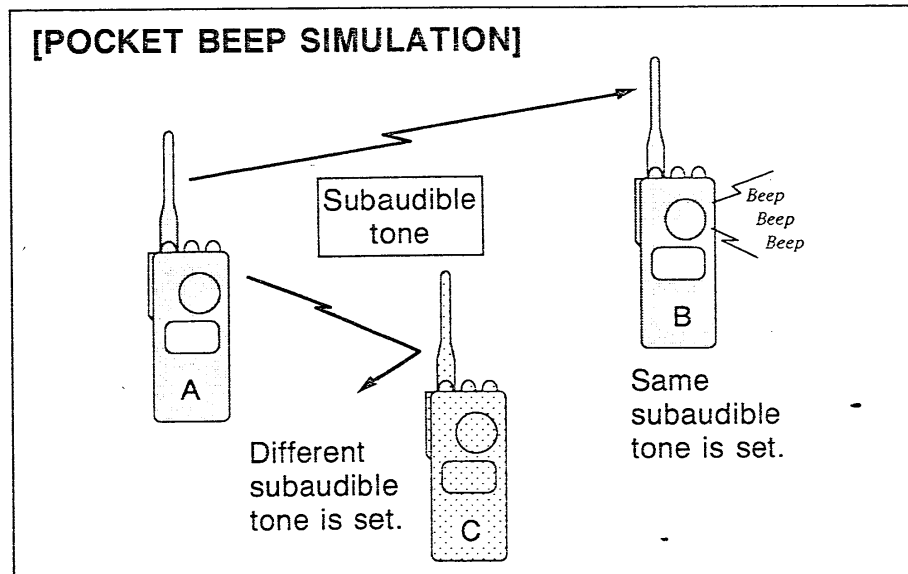

1. Set the operating frequency.

Push [$\text{\textcircled{A}}$ CLR]; then, rotate the main dial to set the operating frequency.

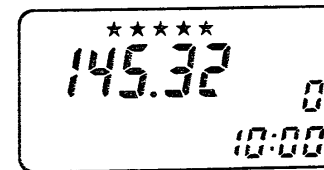
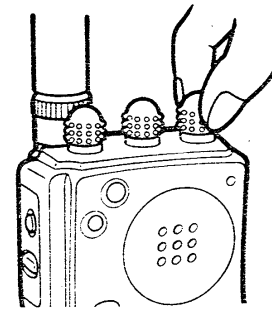

2. Set the tone frequency.

While pushing [FUNC], push [$\text{\textcircled{8}}$ SET]; then, push [$\text{\textcircled{*}}$ ∇] or [$\text{\textcircled{\#}}$ Δ] to select the subaudible tone setting display.

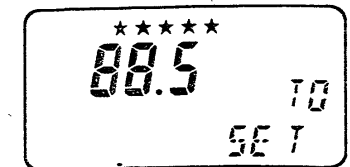

Rotate the main dial to set the subaudible tone frequency.



Push [$\text{\textcircled{A}}$ CLR] to exit.

3. Turn the pocket beep ON.

While pushing [FUNC], push [① T/T SQL] several times until "T SQL (••)" appears on the function display.

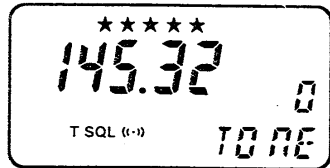
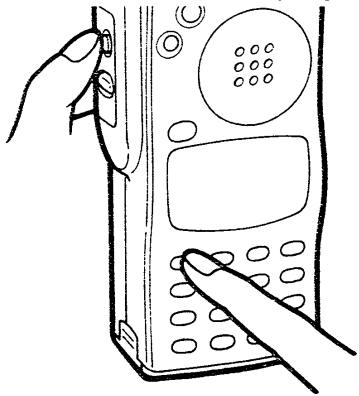

- Turn OFF an optional pager or code squelch to activate the pocket beep.

4. Wait for a call.

When a signal including the correct tone is received, the transceiver emits beep tones for 30 sec. and flashes "(••)."

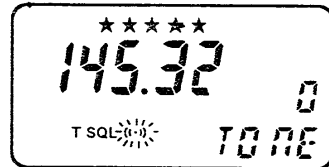

Push [PTT] to transmit an answer back call or [A CLR] to stop the beeps and flashing.

- Tone squelch is automatically selected.



5. Cancel the function.

While pushing [FUNC], push [① T/T SQL] several times until "T SQL" disappears on the function display.

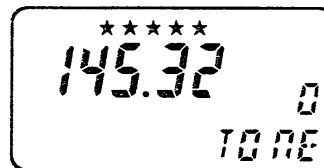
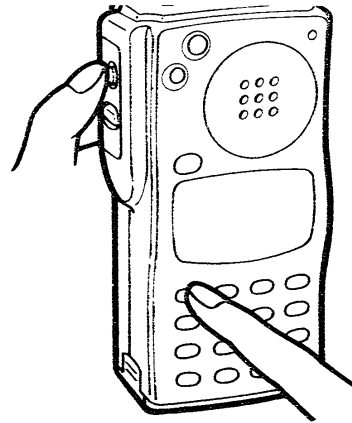

Calling a specific station.

While pushing [FUNC], push [① T/T SQL] several times until "T SQL" appears on the function display.

Push and hold [PTT] for at least 1 sec.

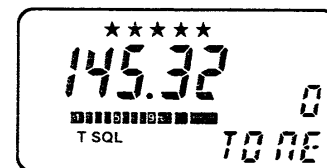
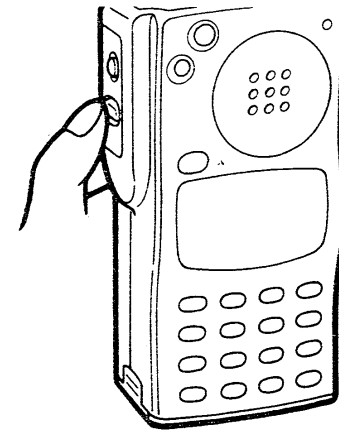

■ Tone squelch operation

An optional UT-50 is necessary for operation.

Tone squelch is used for private communication and allows quiet standby since you will receive calls only from stations which know the subaudible tone frequency programmed into your transceiver. You can use tone squelch simultaneously with the pager or code squelch.

The subaudible tone is superimposed with your transmitting voice signal while you are pushing [PTT] in order to open the tone squelch of the receive station.

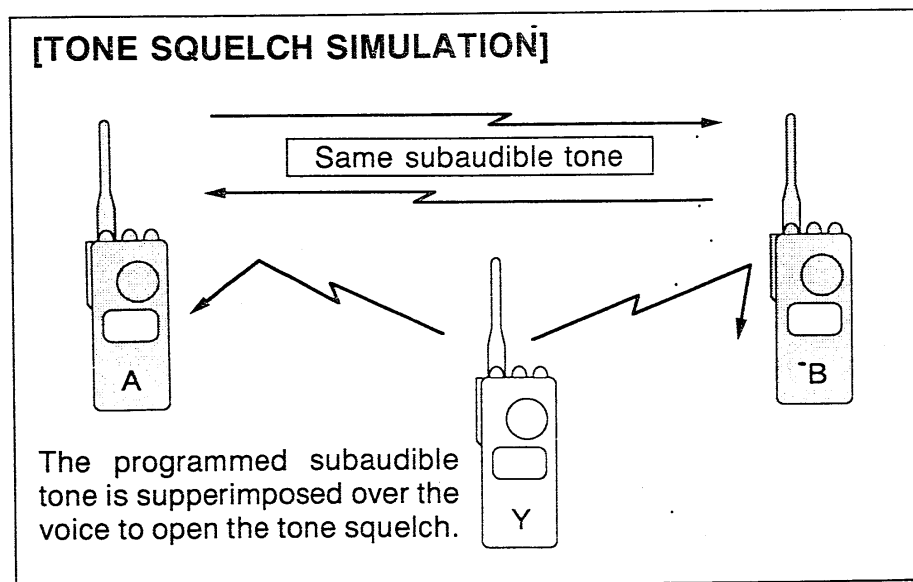

1. Set the operating frequency.

Push [**A** CLR]; then, rotate the main dial to set the operating frequency.

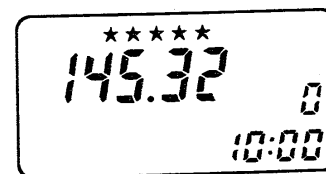
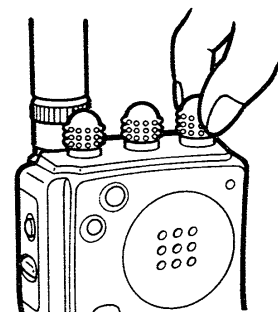

2. Set the tone frequency.

While pushing [FUNC], push [**8** SET]; then, push [***** ▽] or [**#** △] to select the subaudible tone setting display.

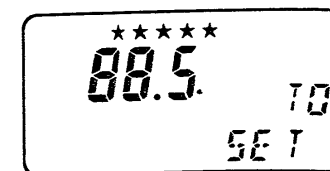

Rotate the main dial to set the subaudible tone frequency.

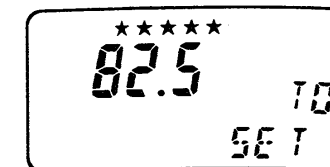

Push [**A** CLR] to exit.

3. Turn the tone squelch ON.

While pushing [FUNC], push [① T/T SQL] several times until "T SQL" appears on the function display.

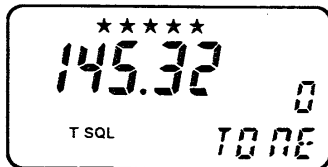
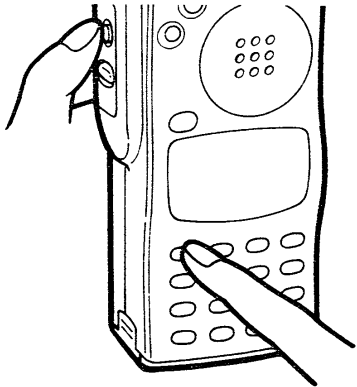

4. Operate the transceiver.

Operate the transceiver in the normal way (push [PTT] to transmit; release [PTT] to receive).

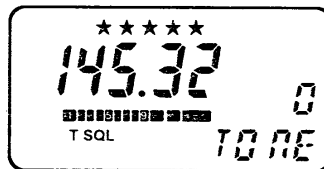
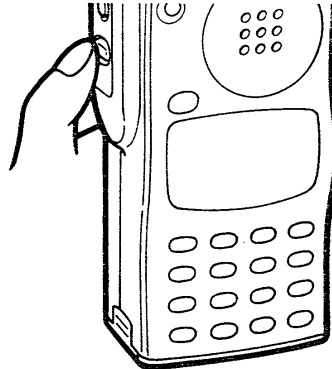

- The programmed subaudible tone is superimposed over the voice to open the tone squelch.
- To open the squelch manually, push and hold [MON!].

5. Cancel the function.

While pushing [FUNC], push [① T/T SQL] to cancel the function.

- "T SQL" disappears.

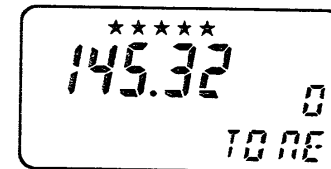
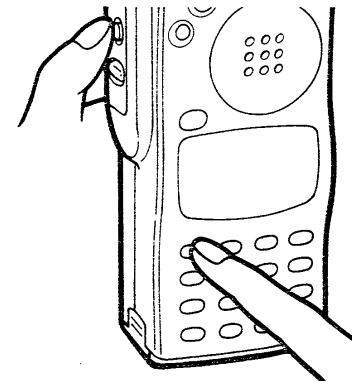

21 TROUBLESHOOTING

■ Troubleshooting

PROBLEM	POSSIBLE CAUSE	SOLUTION	REF.
<ul style="list-style-type: none"> No power comes on. 	<ul style="list-style-type: none"> The battery pack is empty. Poor plug connection to the external DC power cable. 	<ul style="list-style-type: none"> Charge the battery pack or place new dry cell batteries in the battery case. Check the connector or remove and replace the cable. 	See below.*
<ul style="list-style-type: none"> No sound comes from the speaker. 	<ul style="list-style-type: none"> [SQL] is turned too far clockwise. An external speaker or earphone is connected. An optional pager or code squelch is activated. 	<ul style="list-style-type: none"> Rotate the [SQL] control counterclockwise. Unplug the speaker or earphone. While pushing [FUNC], push [② PGR/C-SQL] several times to turn the function OFF. 	<p>p. 21</p> <p>pgs. 71, 75</p>
<ul style="list-style-type: none"> Transmitting is impossible. 	<ul style="list-style-type: none"> The battery pack is empty. The PTT lock function is activated. 	<ul style="list-style-type: none"> Charge the battery pack or place new dry cell batteries in the battery case. Turn OFF the PTT lock function using SET mode. 	<p>pgs. 9, 12</p> <p>p. 53</p>
<ul style="list-style-type: none"> Frequency cannot be set. 	<ul style="list-style-type: none"> The lock function is activated. The memory mode or call channel is selected. 	<ul style="list-style-type: none"> While pushing [FUNC], push [ⓓ LOCK] to turn OFF the lock function. Push [Ⓐ CLR] once or twice to select VFO mode. 	<p>p. 14</p> <p>p. 13</p>
<ul style="list-style-type: none"> Scan cannot be activated. 	<ul style="list-style-type: none"> The call channel is selected. Priority watch is activated. The squelch is open. 	<ul style="list-style-type: none"> Push [ⓓ CALL] to exit the call channel. Push [Ⓐ CLR] to deactivate the priority watch. Rotate the [SQL] control clockwise. 	<p>p. 28</p> <p>p. 44</p> <p>p. 32</p>
<ul style="list-style-type: none"> The contents of the memories are erased. 	<ul style="list-style-type: none"> The backup battery is exhausted because no charging has been performed for a long time. 	<ul style="list-style-type: none"> Charge the battery pack or place new dry cell batteries in the battery case. (Backup battery is charged simultaneously.) 	p. 2
<ul style="list-style-type: none"> Some standard functions cannot be activated. 	<ul style="list-style-type: none"> All 5 star marks (★) do not appear on the function display. 	<ul style="list-style-type: none"> While pushing [AI] and [H/L/DTMF], turn power ON. Then push [PTT] to activate all functions. 	Separate

*If you have any questions, please contact your local Icom dealer.

■ Exiting a display

When the transceiver shows the following displays, operate as follows to exit the display, if desired.



The display appears when the transceiver is in the AI selection mode. To exit the mode, push [AI]. (p. 58)



The display appears when the code channel display is selected. To exit the display, push [PTT]. (p. 70)

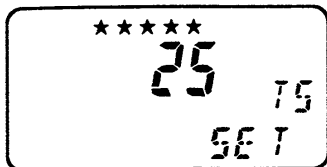

The display appears when the SET mode is selected. To exit the display, push [PTT] or [A CLR]. (p. 51)

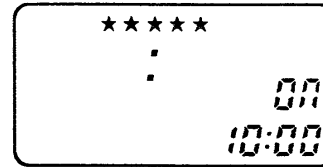

The display appears when the TIMER mode is selected. To exit the display, push [PTT]. (p. 59)

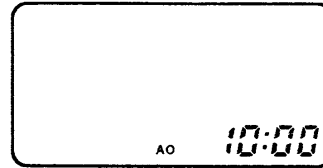

The display appears when the transceiver enters the OFF condition by the auto power-off or power-off timer. To exit the display, turn [PWR/VOL] OFF then ON again. (p. 64)

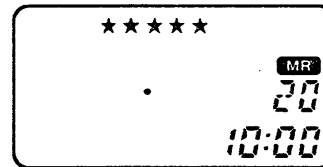

The display appears when a masked memory channel is selected. To exit the display, rotate the main dial to select an unmasked memory channel. (p. 24)

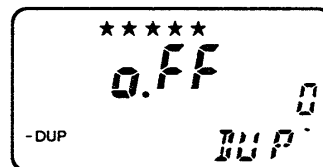

The display appears when the transmit frequency is off-band in duplex operation. To exit the display, check and reset the operating frequency, duplex direction and offset frequency. (p. 39)

22 SPECIFICATIONS

IC-P2AT/ET

General

- Frequency coverage

VERSION	FREQUENCY COVERAGE
IC-P2AT (U.S.A., Asia)	140 ~ 150 MHz* ¹ (Transmit) 138 ~ 174 MHz* ¹ (Receive)
IC-P2ET (Italy)	140 ~ 150 MHz* ¹
IC-P2ET (Except Italy)	144 ~ 146 MHz
IC-P2AT (Australia)	144 ~ 148 MHz

*¹Guaranteed frequency coverage is 144 ~ 148 MHz

- Mode : FM
- Frequency stability : ± 5 ppm (0°C ~ +50°C;
+32°F ~ +122°F)
- Antenna impedance : 50 Ω (nominal)
- Usable battery pack or case : BP-110 ~ BP-114
- External DC power supply : 6 ~ 16 V DC (negative ground)
- Current drain : Transmit
(at 13.8 V DC, typical) High 1.5 A
Low 1 650 mA
Receive
Power saved 16 mA
Rated audio output 250 mA
- Tuning steps : 5, 10, 12.5, 15, 20, 25, 30 and
50 kHz.
- Dial select steps : 100 kHz and 1 MHz
- Usable temperature range : -10°C ~ +60°C;
+14°F ~ +140°F
- Dimensions (with BP-111, : 49(W) \times 105(H) \times 38.5(D) mm
projections not included) 2.1(W) \times 4.9(H) \times 1.5(D) in
- Weight (with BP-111) : 280 g; 9.9 oz

Transmitter

- Output power (at 13.8 V DC): 5.0 W, 3.5 W, 1.5 W and 500 mW
selectable
- Modulation system : Variable reactance frequency
modulation
- Max. frequency deviation : ± 5 kHz
- Spurious emissions : Less than -60 dB
- Microphone impedance : 2 k Ω
- Duty cycle : Transmit : Receive =
1 min. : 3 min.

Receiver

- Receive system : Double-conversion
superheterodyne
- Intermediate frequencies : 1st 30.875 MHz
2nd 455 kHz
- Sensitivity : Less than 0.16 μ V for 12 dB SINAD
- Squelch sensitivity : Less than 0.1 μ V at threshold
- Selectivity : More than 15 kHz/ -6 dB
Less than 30 kHz/ -60 dB
- Spurious response rejection : Less than -60 dB
- Audio output power : 200 mW at 10% distortion with an
8 Ω load.
- Audio output impedance : 8 Ω

All stated specifications are subject to change without notice or obligation.

IC-P4AT/ET

General

- Frequency coverage : U.S.A. version 440~450 MHz
Other versions 430~440 MHz
- Mode : FM
- Frequency stability : ± 5 ppm ($0^{\circ}\text{C} \sim +50^{\circ}\text{C}$;
 $+32^{\circ}\text{F} \sim +122^{\circ}\text{F}$)
- Antenna impedance : 50 Ω (nominal)
- Usable battery pack or case : BP-110~BP-114
- External DC power supply : 6~16 V DC (neative ground)
- Current drain : Transmit
(at 13.8 V DC, typical) : High 1.8 A
Low 1 950 mA
Receive
Power saved 19 mA
Rated audio output 250 mA
- Tuning steps : 5, 10, 12.5, 15, 20, 25, 30 and
50 kHz.
- Dial select steps : 100 kHz and 1 MHz
- Usable temperature range : $-10^{\circ}\text{C} \sim +60^{\circ}\text{C}$;
 $+14^{\circ}\text{F} \sim +140^{\circ}\text{F}$
- Dimensions (with BP-111, : 49(W) \times 105(H) \times 38.5(D) mm
projections not included) 2.1(W) \times 4.9(H) \times 1.5(D) in
- Weight (with BP-111) : 280 g; 9.9 oz

Transmitter

- Output power (at 13.8 V DC): 5.0 W, 3.5 W, 1.5 W and 500 mW
selectable
- Modulation system : Variable reactance frequency
modulation
- Max. frequency deviation : ± 5 kHz
- Spurious emissions : Less than -60 dB
- Microphone impedance : 2 k Ω
- Duty cycle : Transmit : Receive =
1 min. : 3 min.

Receiver

- Receive system : Double-conversion
superheterodyne
- Intermediate frequencies : 1st 30.875 MHz
2nd 455 kHz
- Sensitivity : Less than 0.16 μV for 12 dB SINAD
- Squelch sensitivity : Less than 0.1 μV at threshold
- Selectivity : More than 15 kHz/ -6 dB
Less than 30 kHz/ -60 dB
- Spurious response rejection : Less than -60 dB
- Audio output power : 200 mW at 10% distortion with an
8 Ω load.
- Audio output impedance : 8 Ω

All stated specifications are subject to change without notice or obligation.

Count on us!

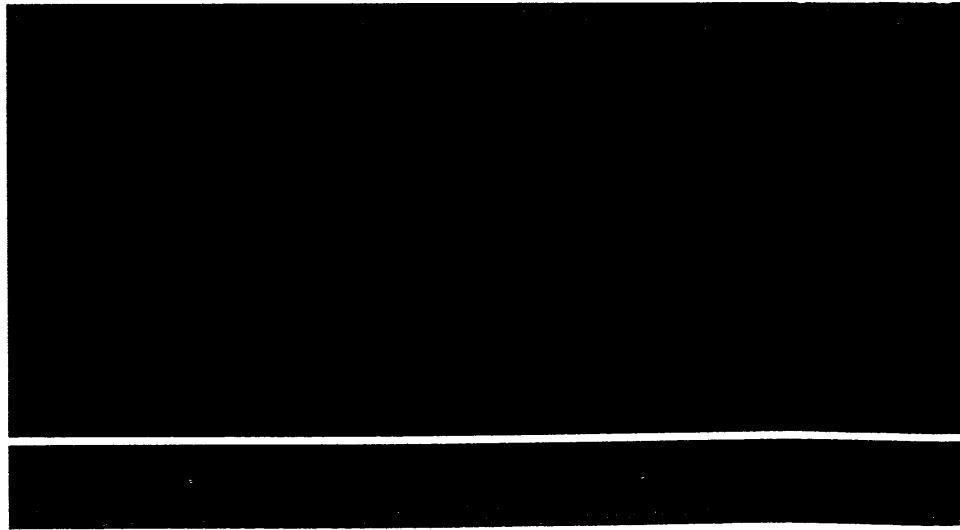

A-5181S-1EX
Printed in Japan
Copyright © 1991 by Icom Inc.

Icom Inc.
6-9-16, Kamihigashi, Hirano-ku, Osaka 547, Japan